

EJERCICIOS PARA TRABAJAR LA ATENCIÓN Y LA MEMORIA

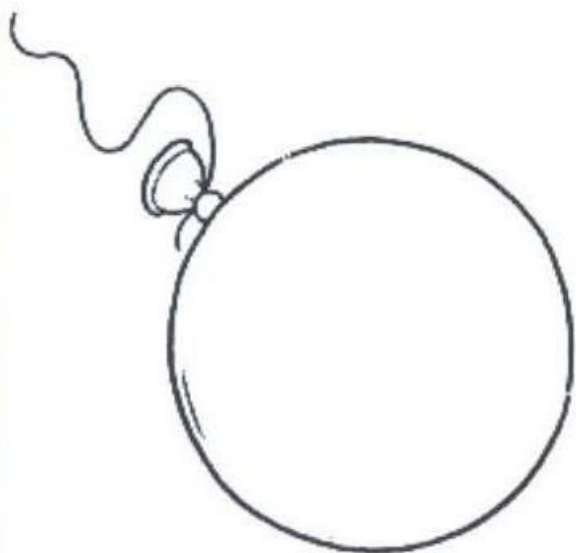

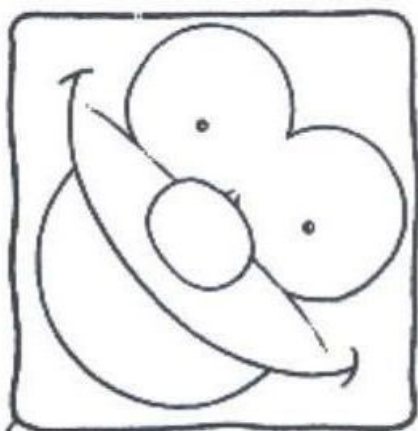

RECONOCIMIENTO DE PROPIEDADES
Pinta los objetos redondos.

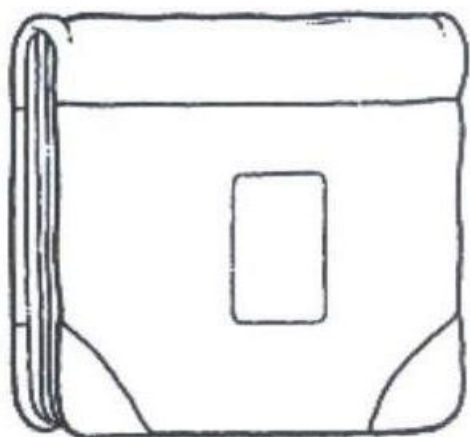



RECONOCIMIENTO DE PROPIEDADES
Pinta los objetos cuadrados.

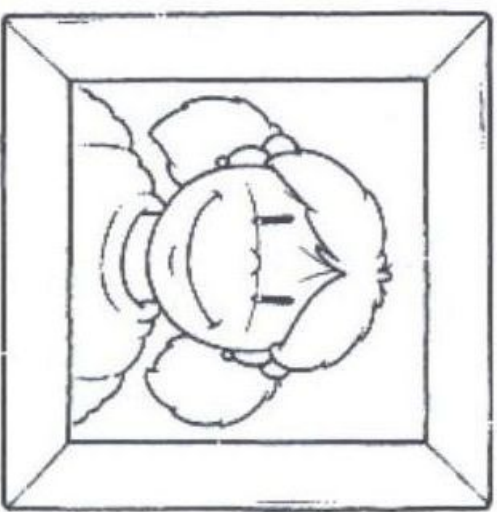
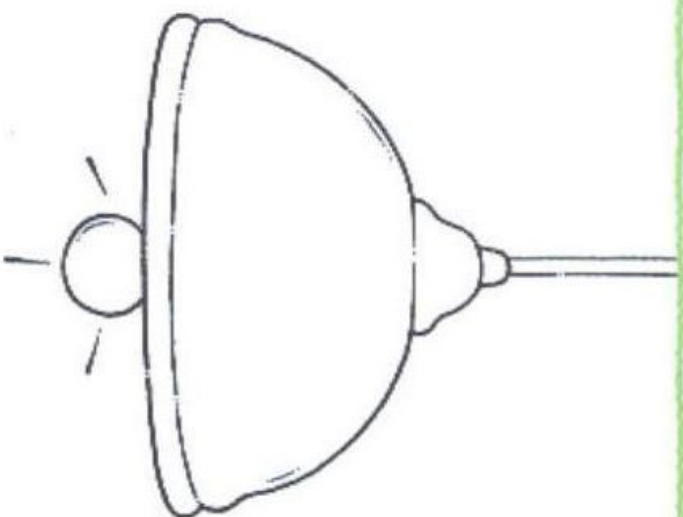
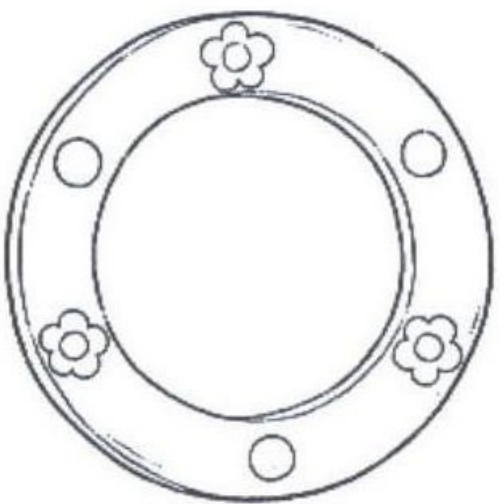
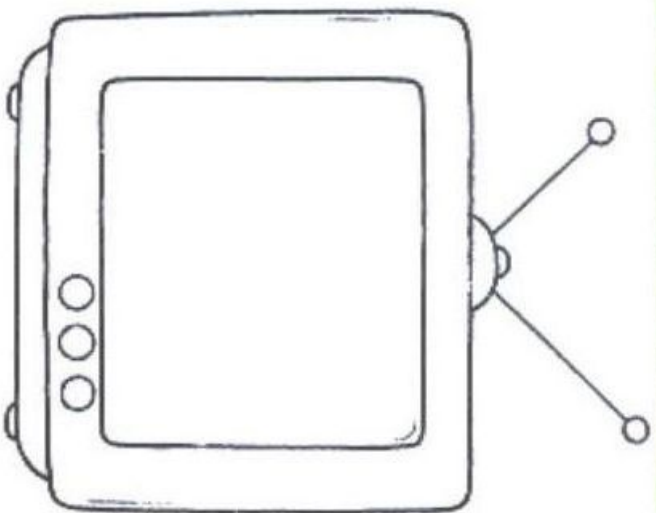



DIBUJOS INCOMPLETOS

Dibuja lo que le falta a cada uno de estos objetos:

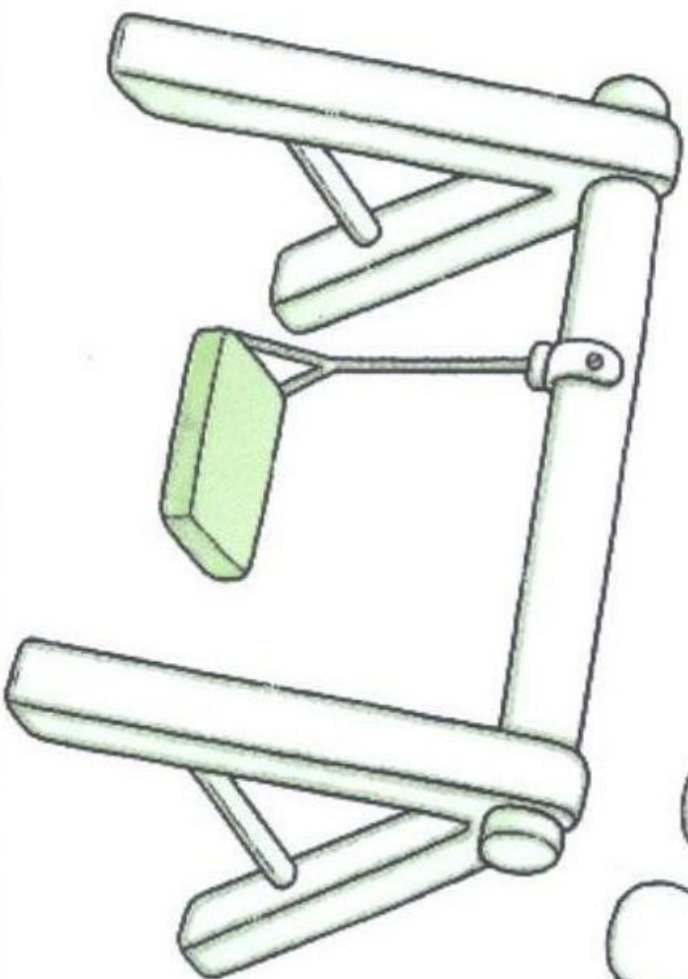
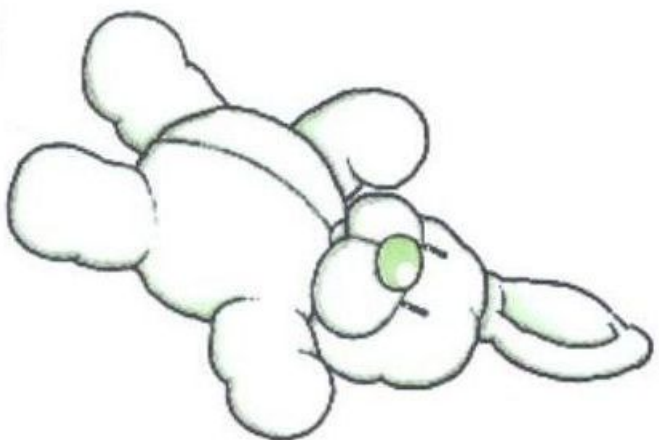
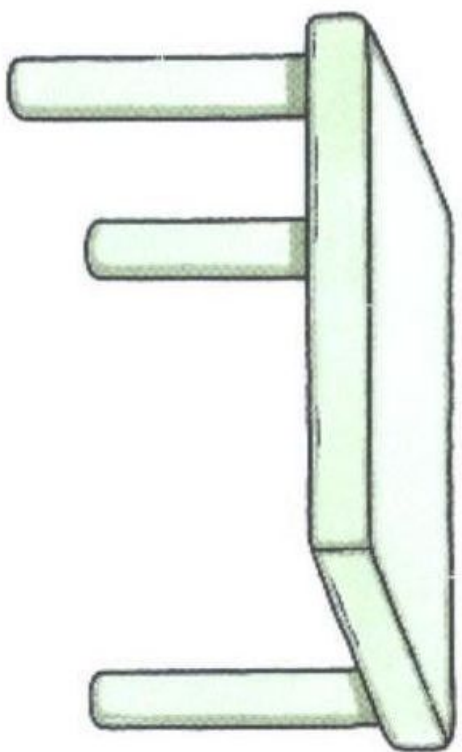



RECONOCIMIENTO DE PROPIEDADES

Pinta de color azul las perlas grandes. Tacha las pequeñas.

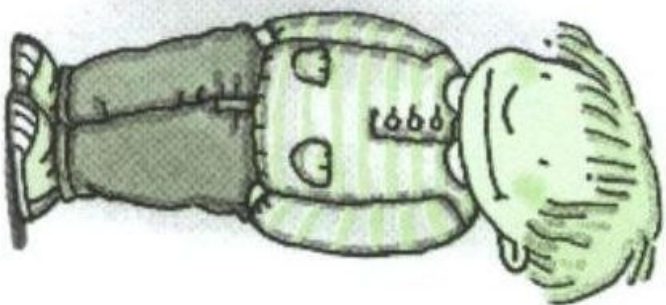



DIBUJOS INCOMPLETOS

Dibuja lo que le falta al auto. Píntalo.

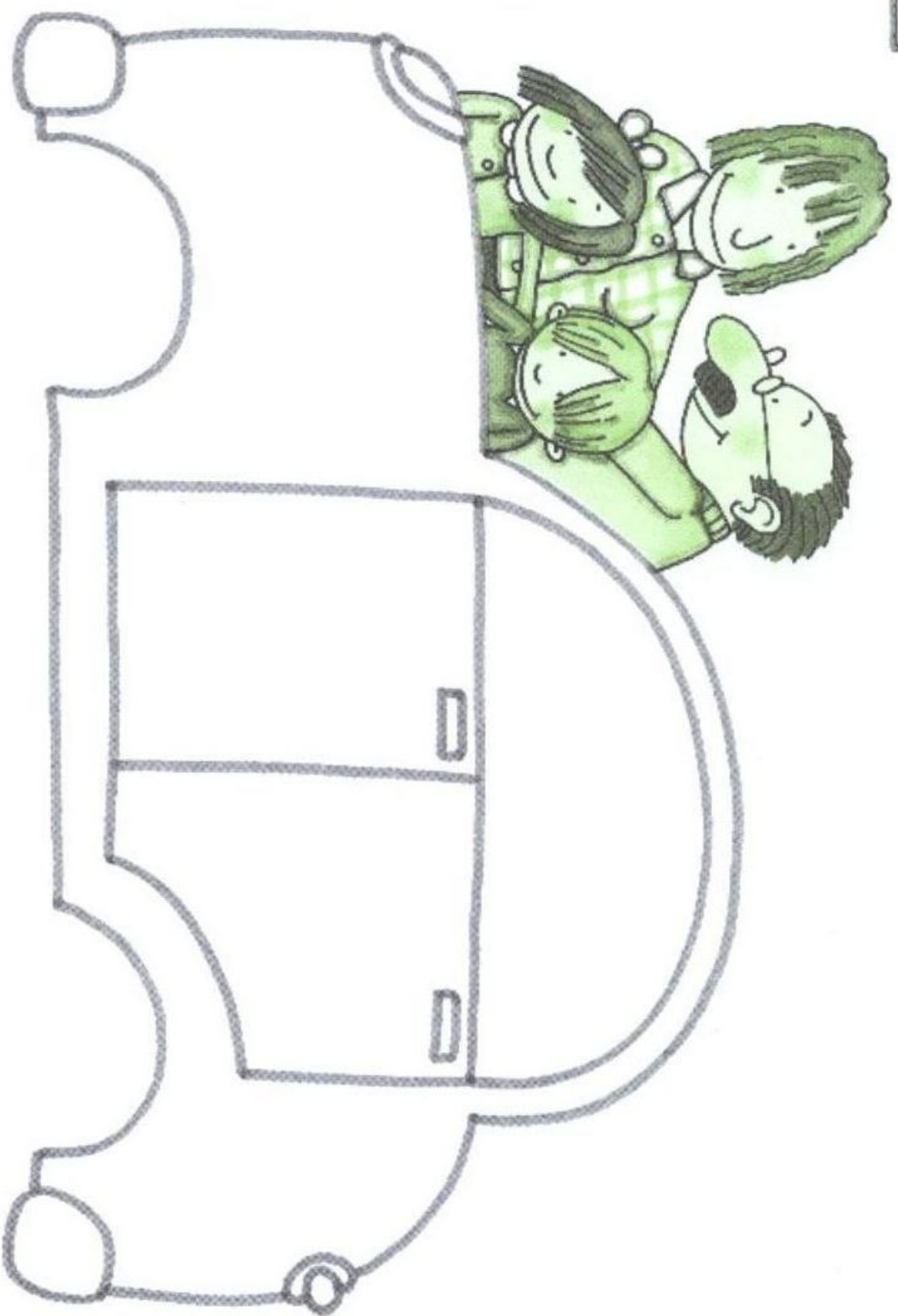

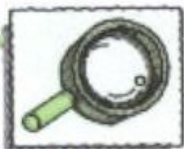

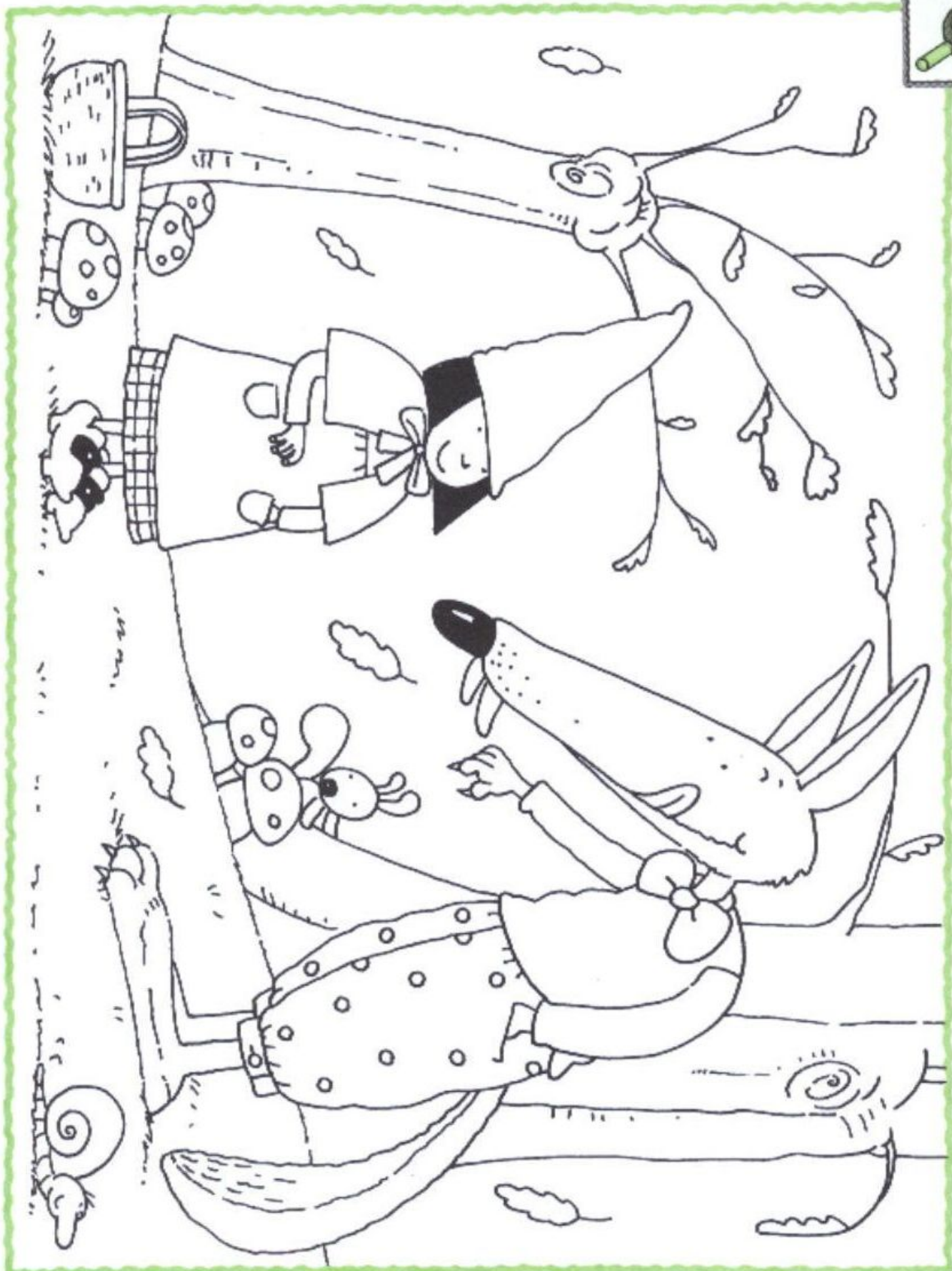

OBJETOS ESCONDIDOS

Pinta el dibujo. Encierra lo que perdió Caperucita.



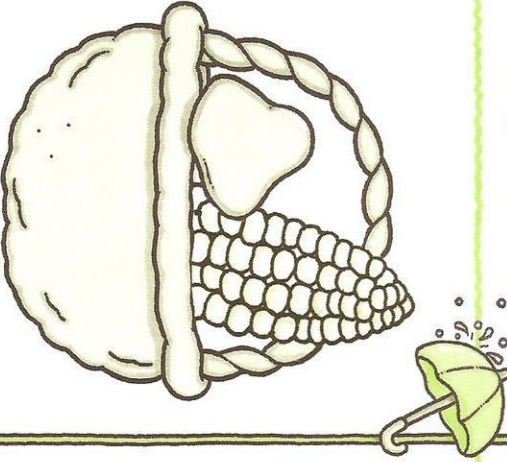
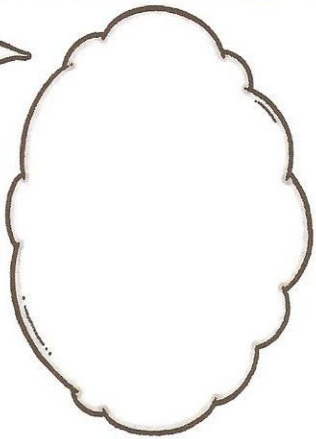
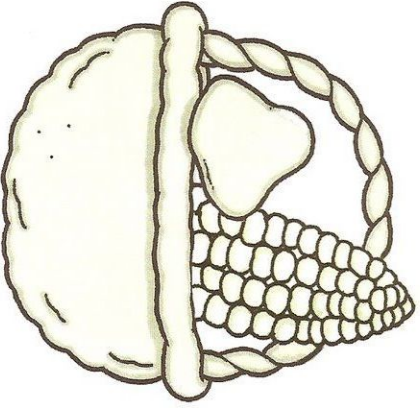

SEMELJANZAS Y DIFERENCIAS
Encierra el dibujo igual al modelo.

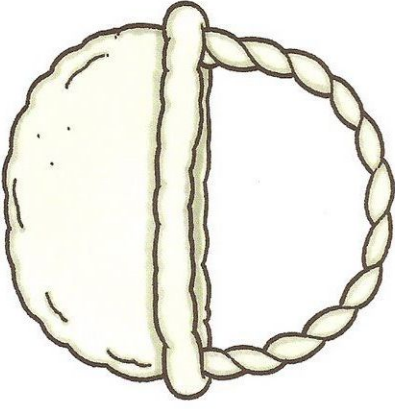
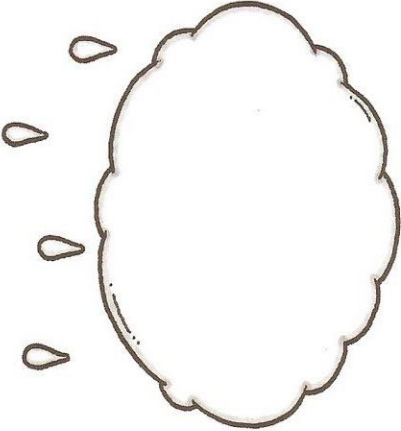



DIBUJOS INCOMPLETOS

Completa los dibujos. Píntalos.

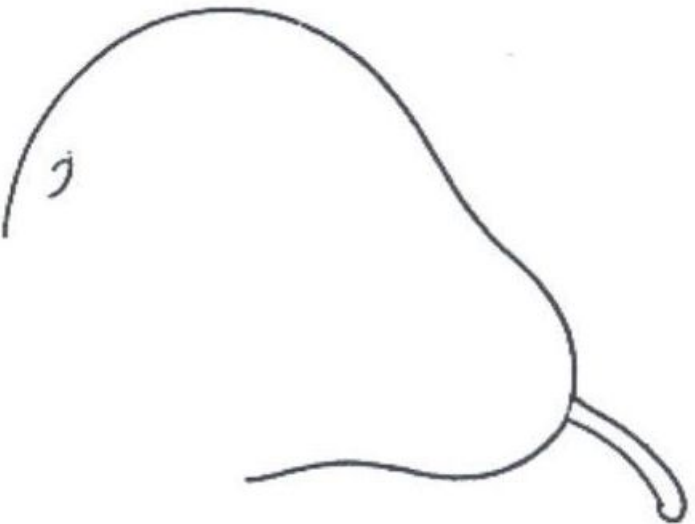
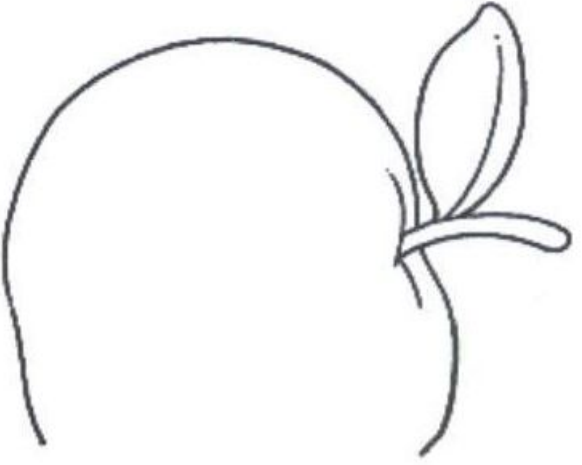
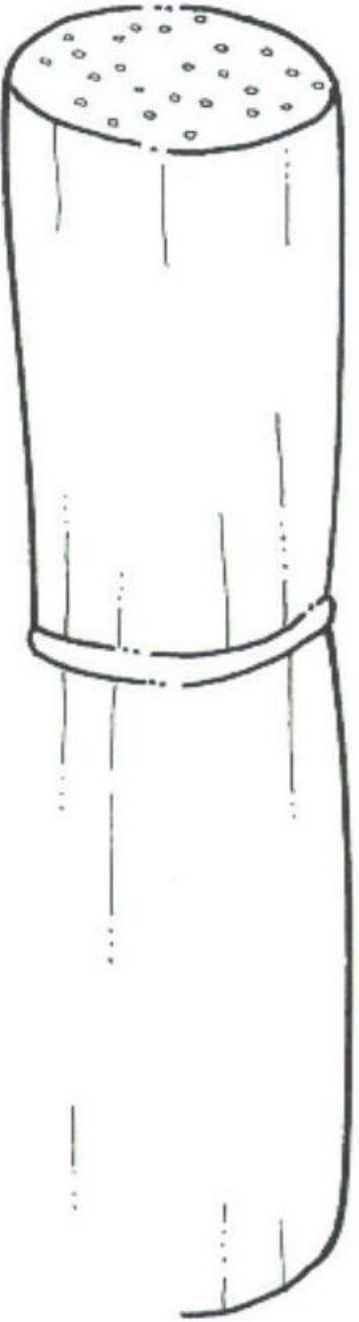

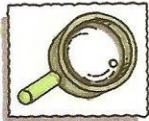

SEMEJANZAS Y DIFERENCIAS
Une con flechas las figuras iguales. Pinta.





FIGURA - FONDO

Busca la manzana y píntala.



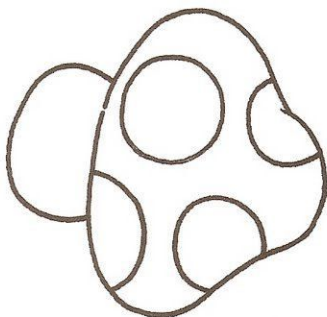
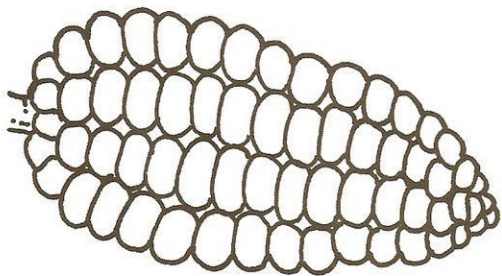
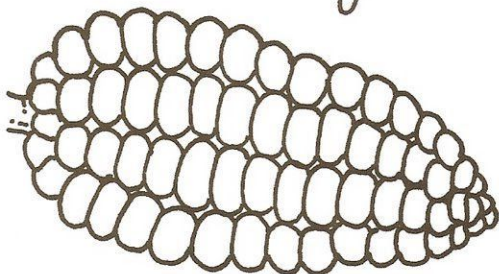
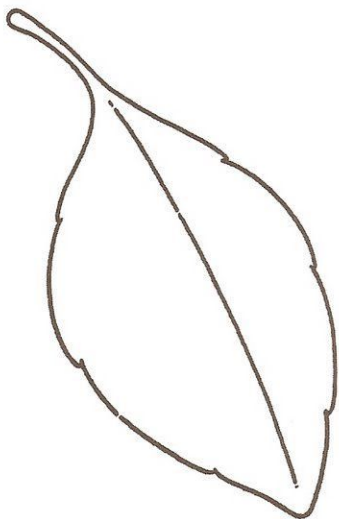
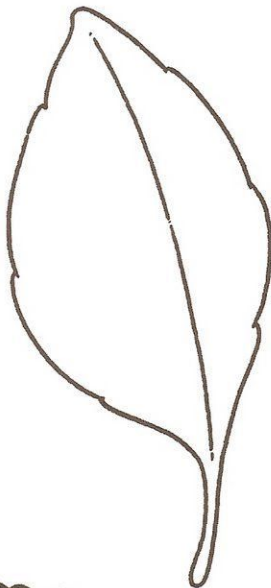
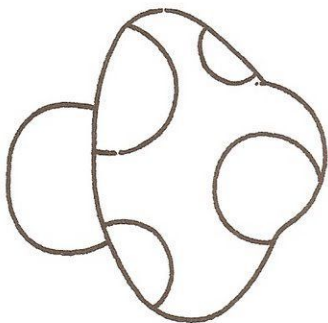
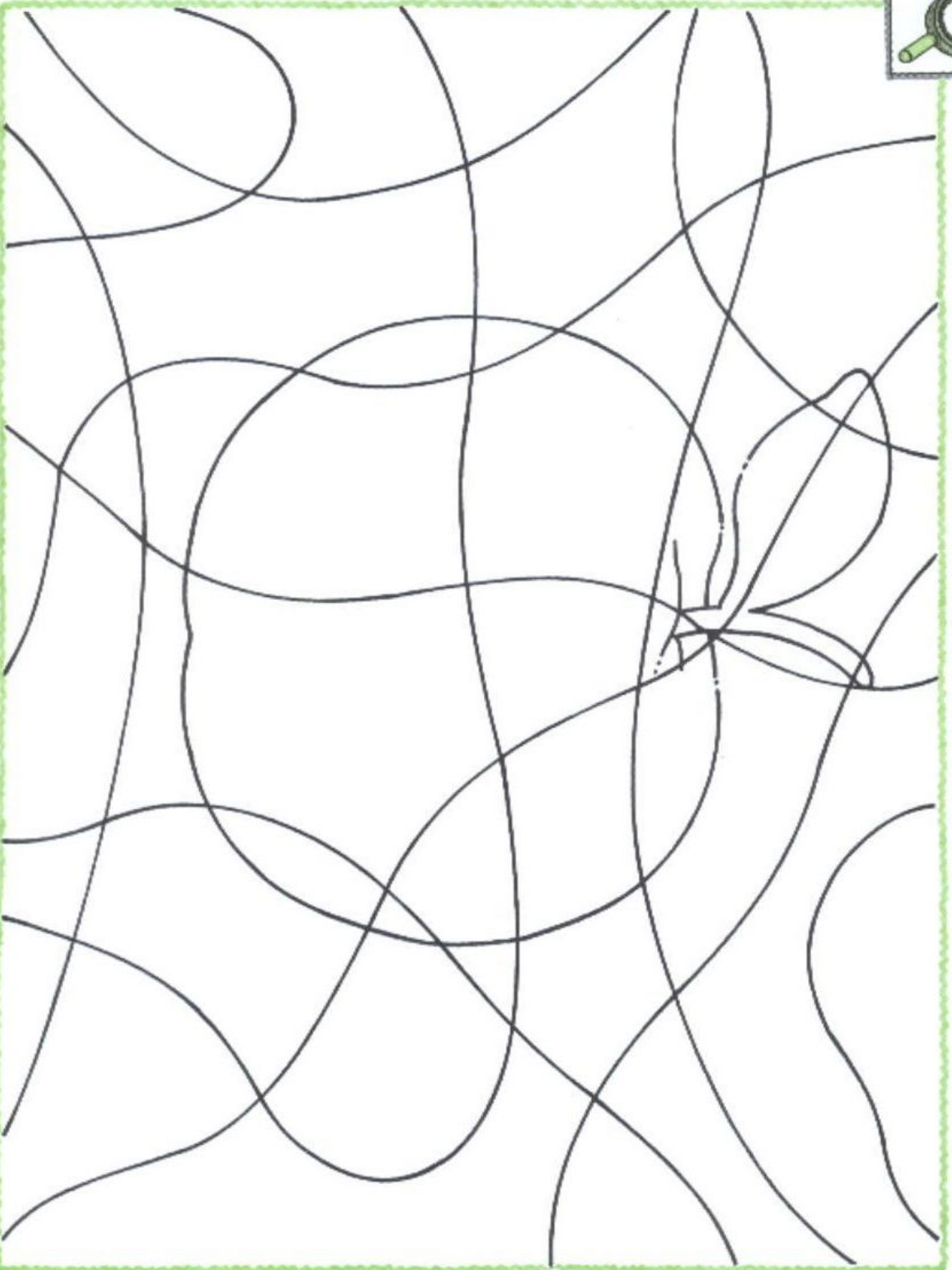
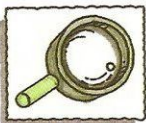

RECONOCIMIENTO DE PROPIEDADES
Pinta los cuadrados y pon un punto en los círculos.

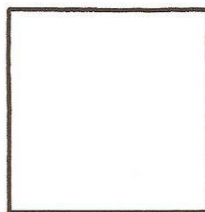
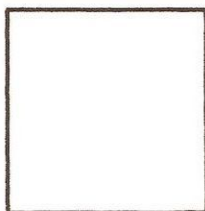
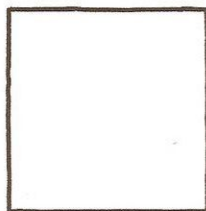
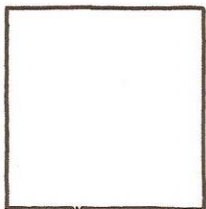
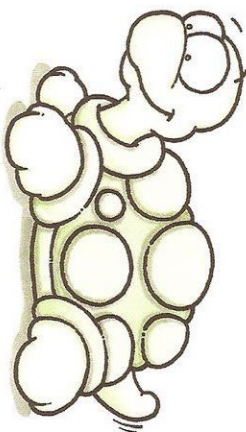
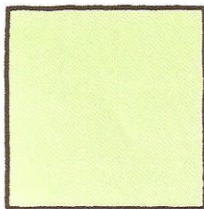

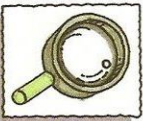

OBJETOS ESCONDIDOS

Busca un gorro, un chaleco, unos guantes y una bufanda. Enciérralos en un círculo.

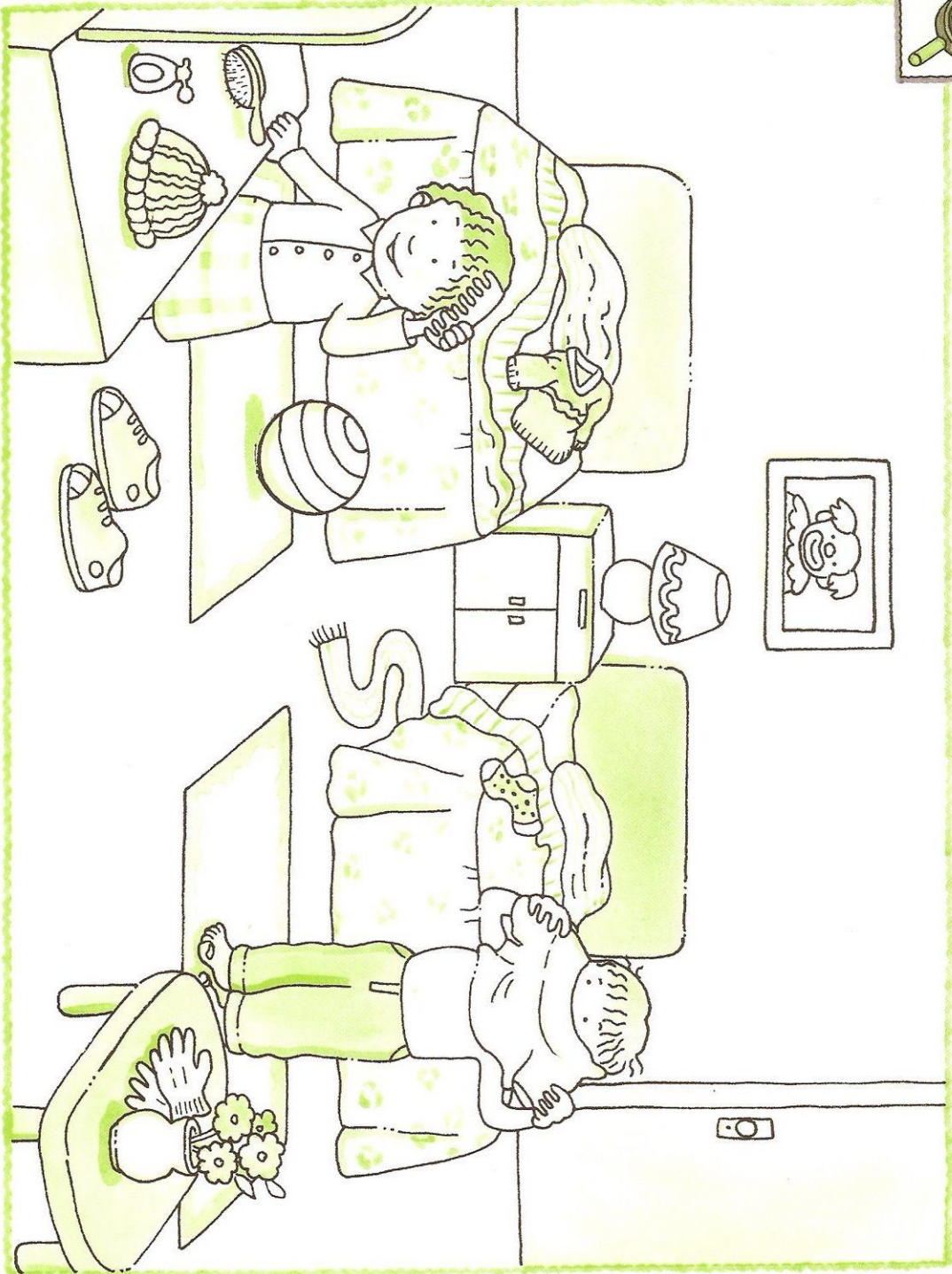



RECONOCIMIENTO DE PROPIEDADES

Pinta los gorros con forma de triángulo.

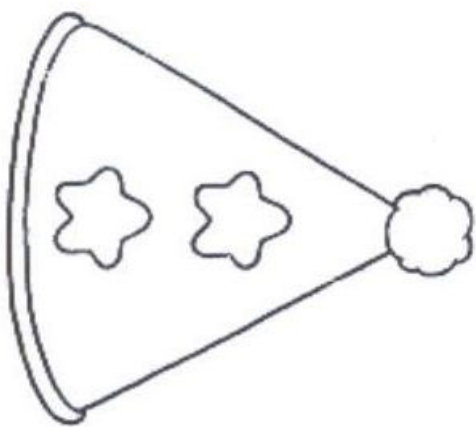
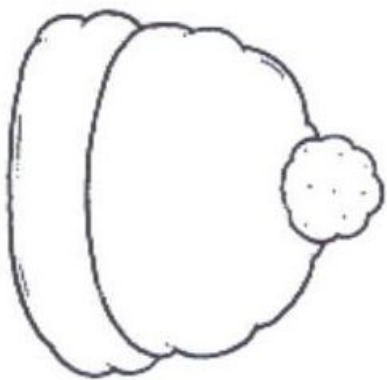
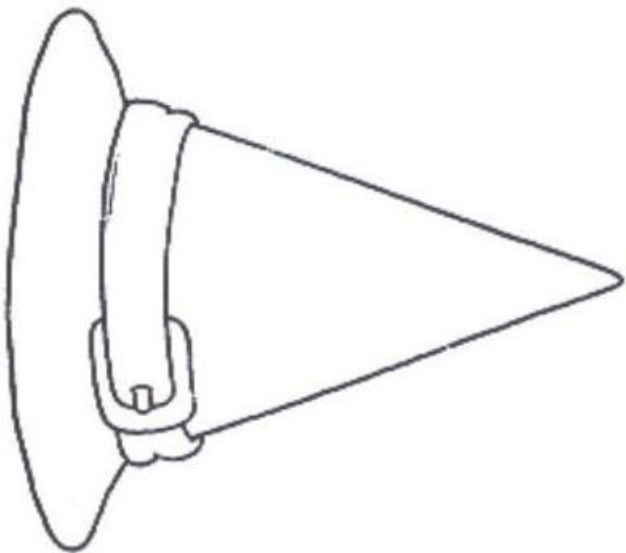
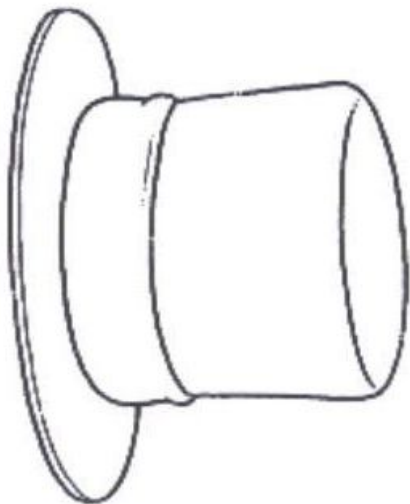
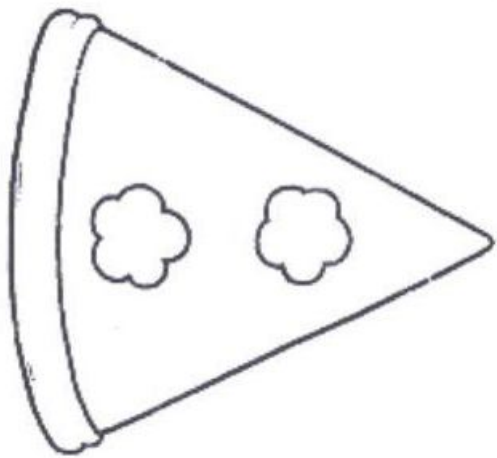



FIGURA - FONDO

Busca una parte de la cara. Píntala.



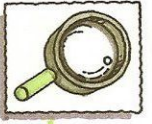
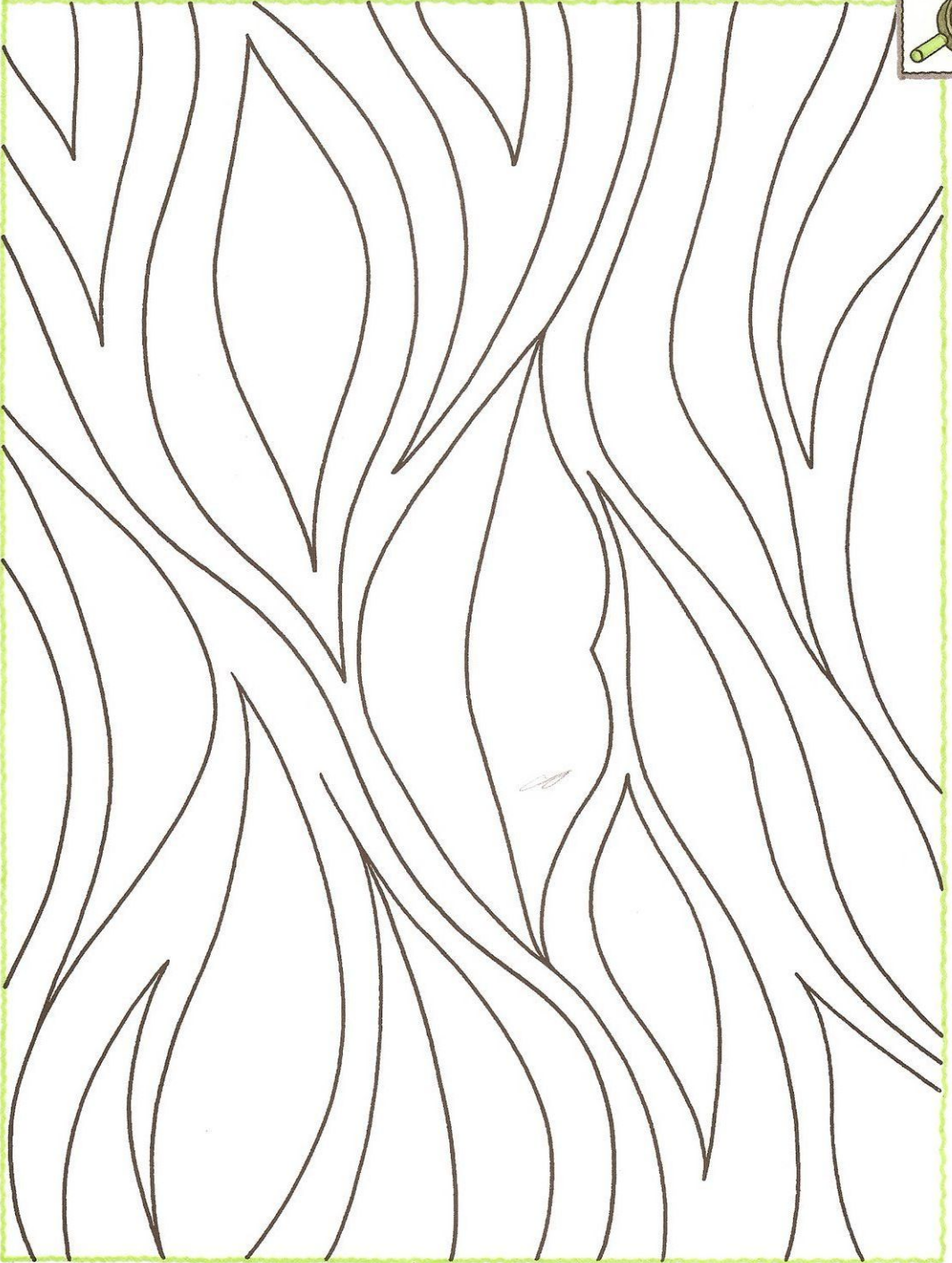

DIBUJOS INCOMPLETOS

Completa la cara del payaso. Píntala.

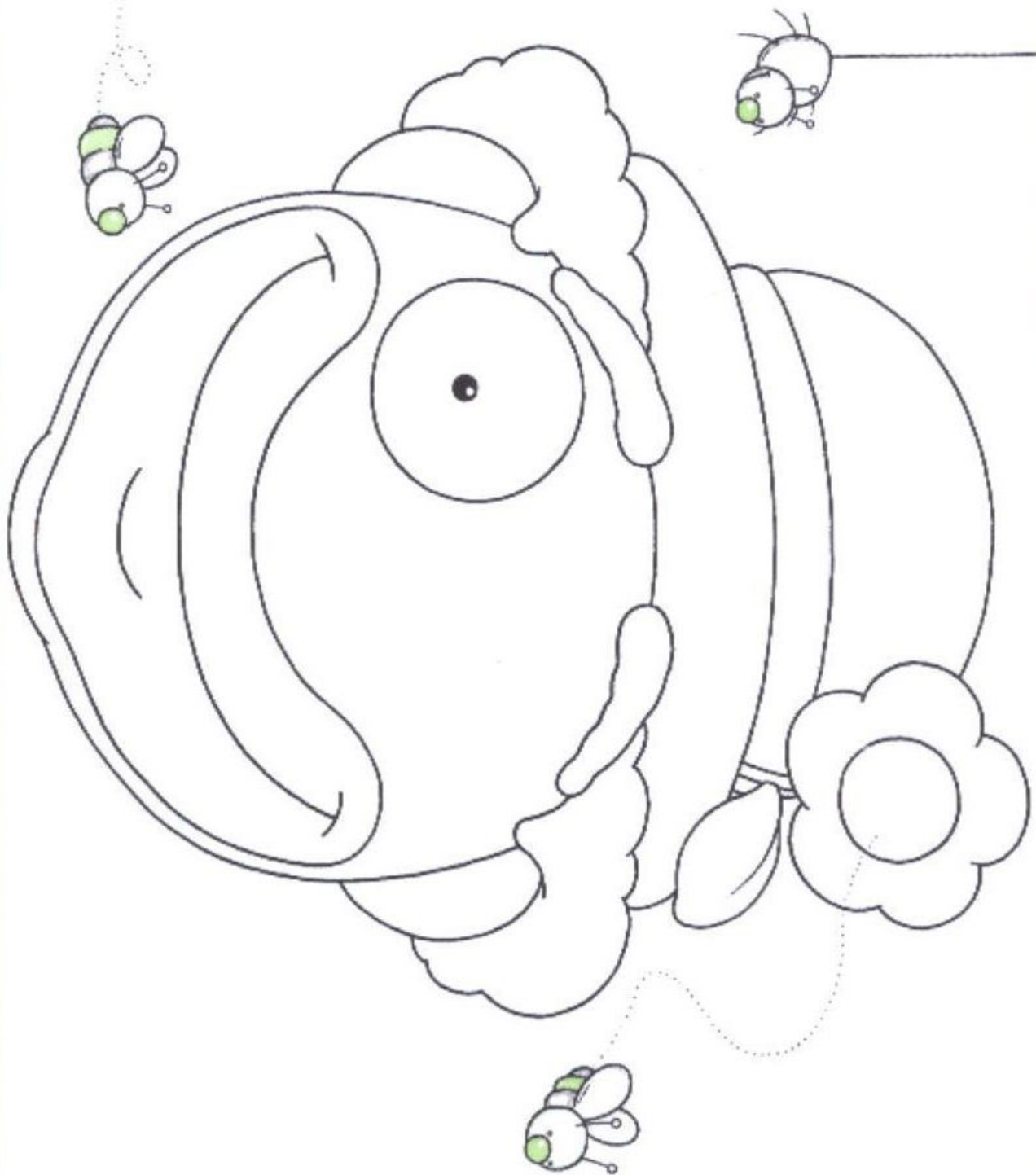



SEMEJANZAS Y DIFERENCIAS

Pinta la chaqueta igual al modelo.

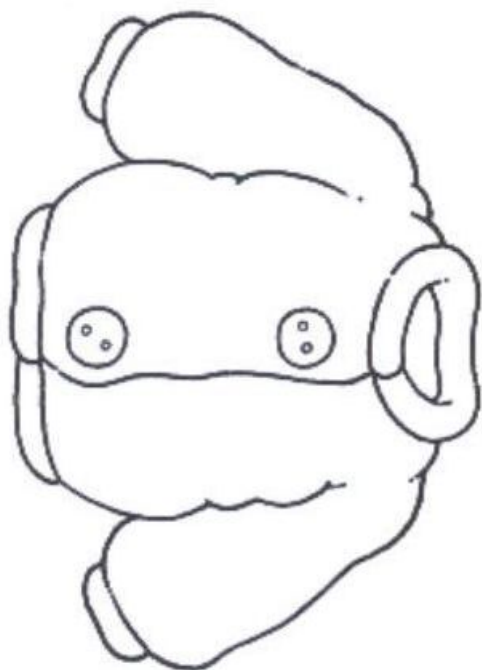
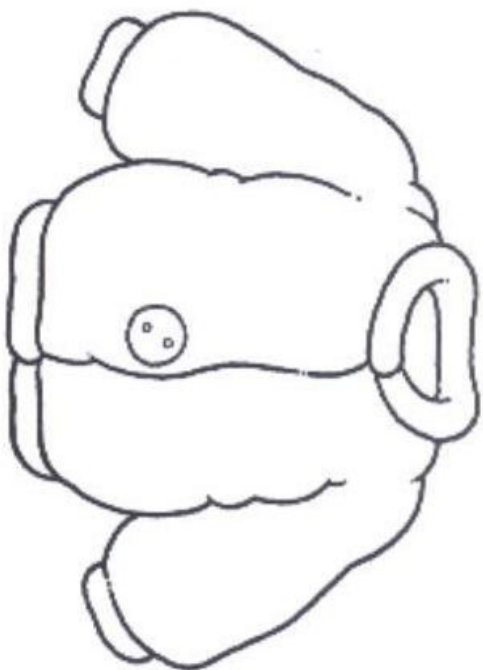
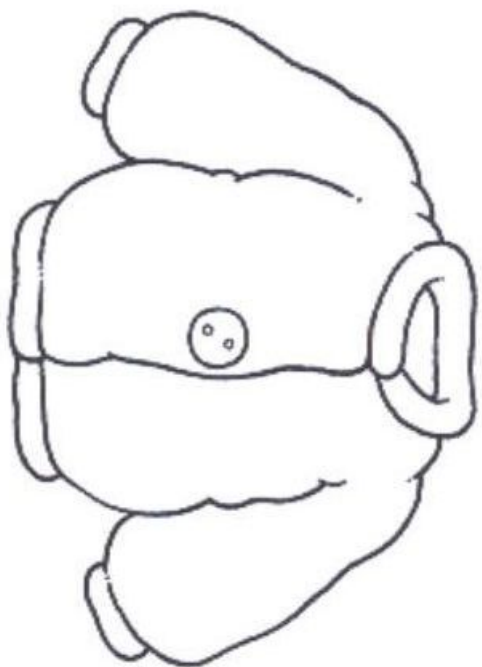
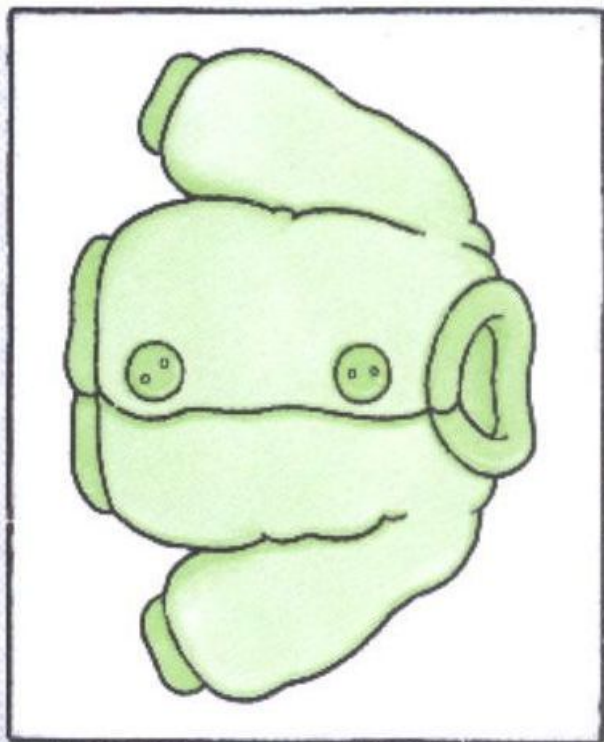



DIBUJOS INCOMPLETOS

Dibuja lo que le falta a cada cara.





RECONOCIMIENTO DE PROPIEDADES
Pinta las figuras **grandes**. Tacha los **triángulos**.

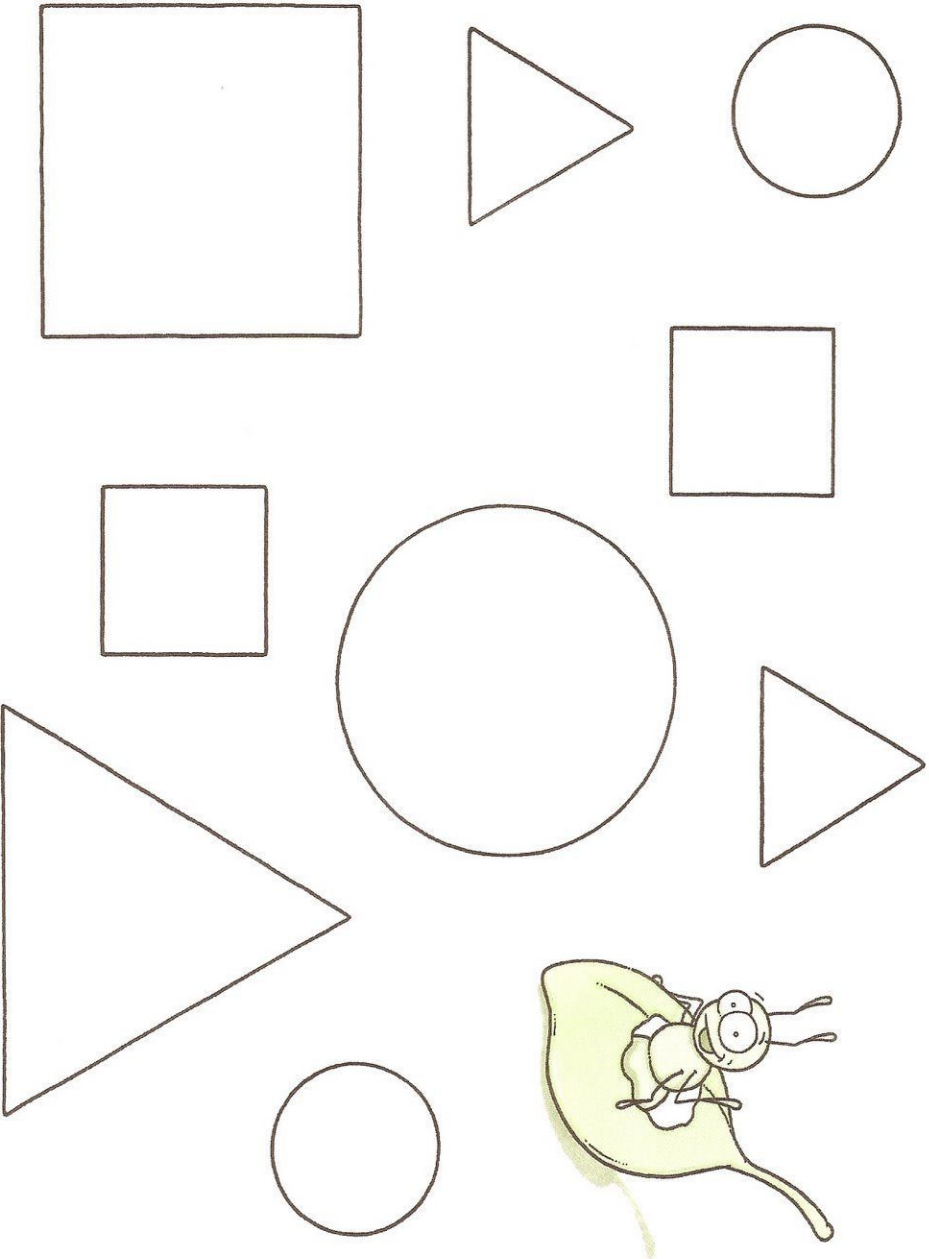



FIGURA - FONDO

Pinta el alimento escondido.



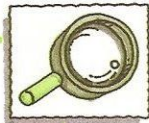
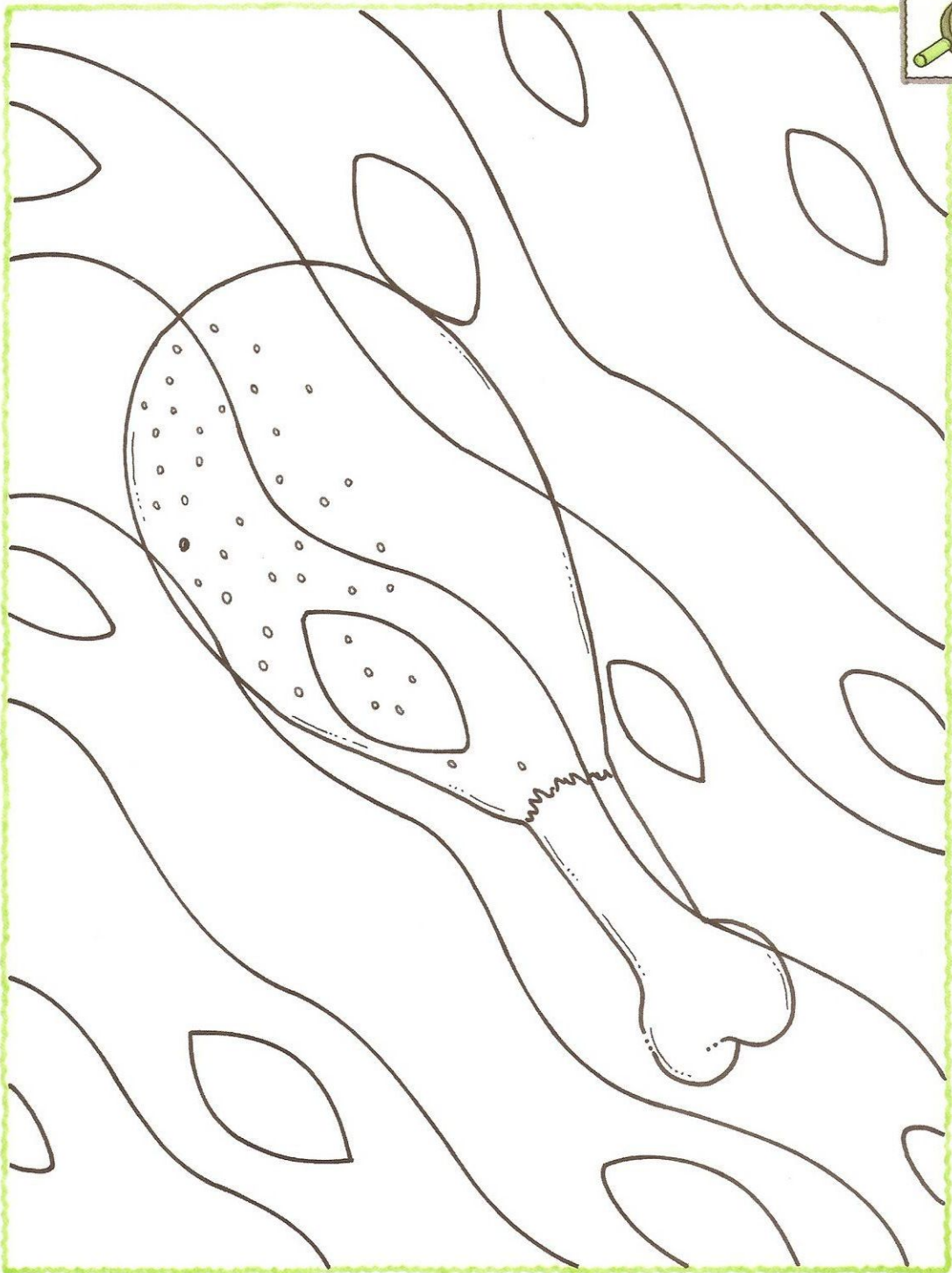
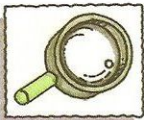

RECONOCIMIENTO DE PROPIEDADES

Pinta la torta más grande.





FIGURA - FONDO

Busca una frutilla. Decórala con pintura digital.

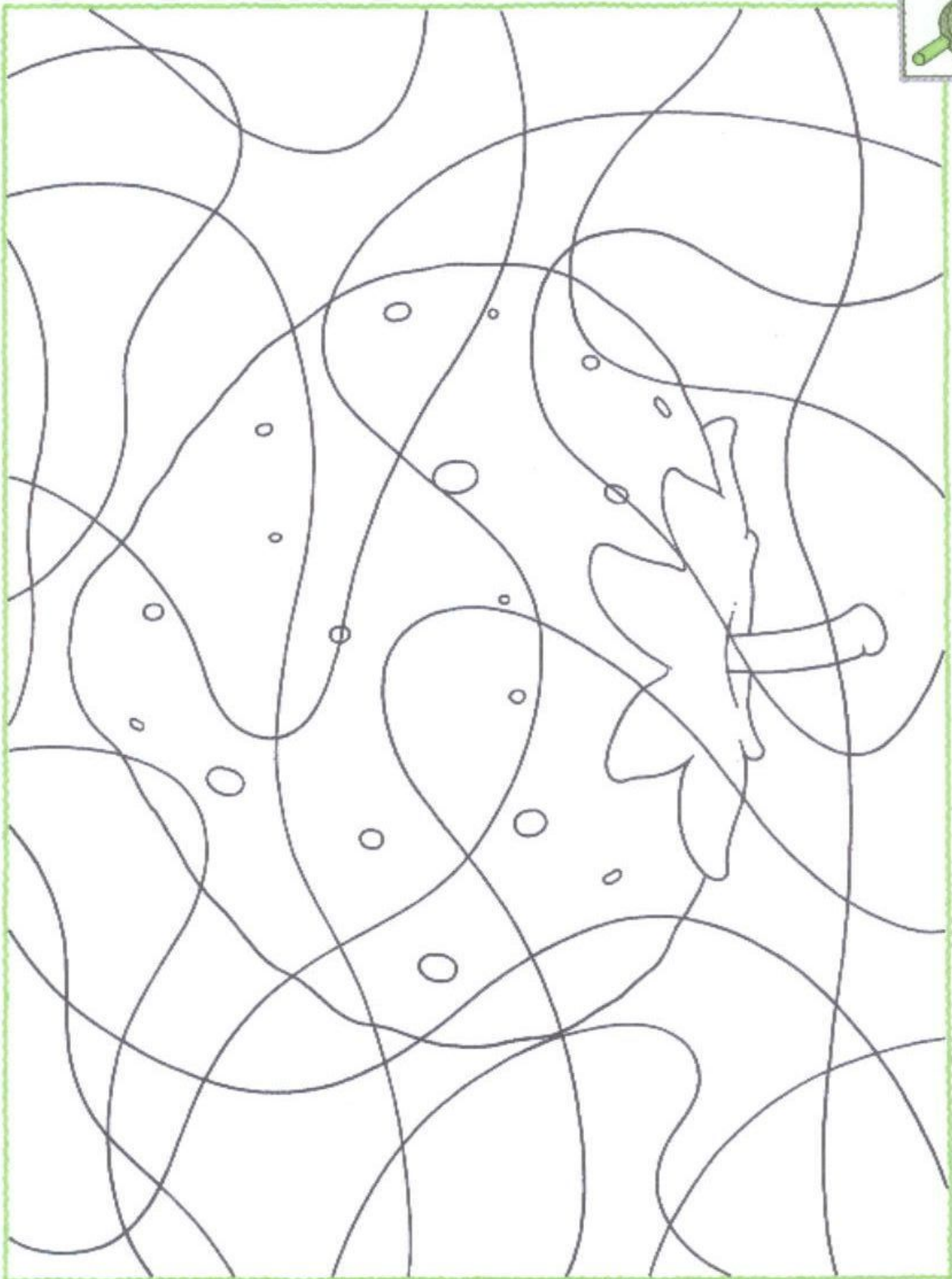

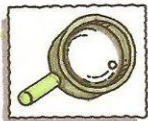

SEMEJANZAS Y DIFERENCIAS
Une con flechas los objetos iguales.

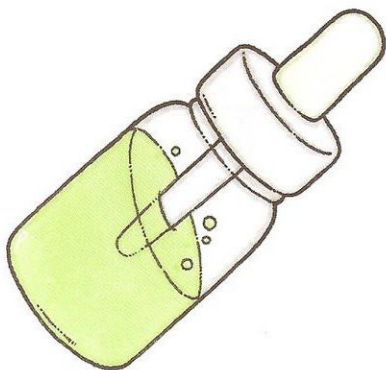
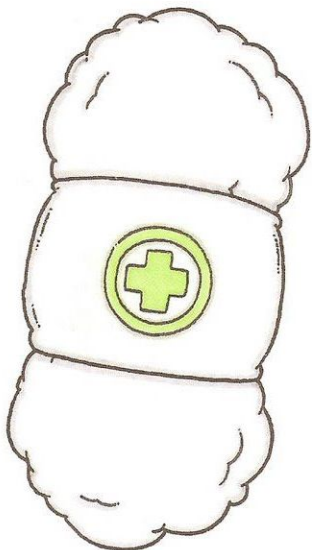
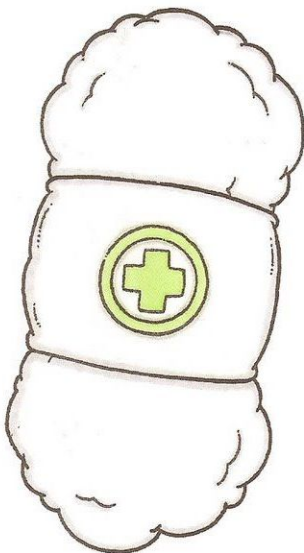
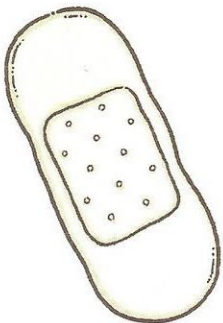
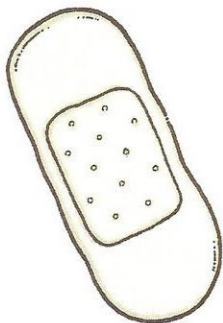
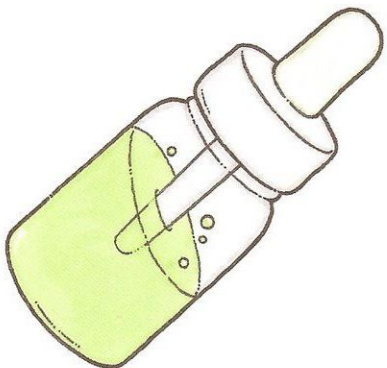

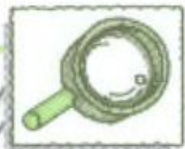

OBJETOS ESCONDIDOS

Busca los plátanos escondidos. Enciérralos en un círculo.





DIBUJOS INCOMPLETOS

Pinta, con pintura digital, la melena que le falta al león.

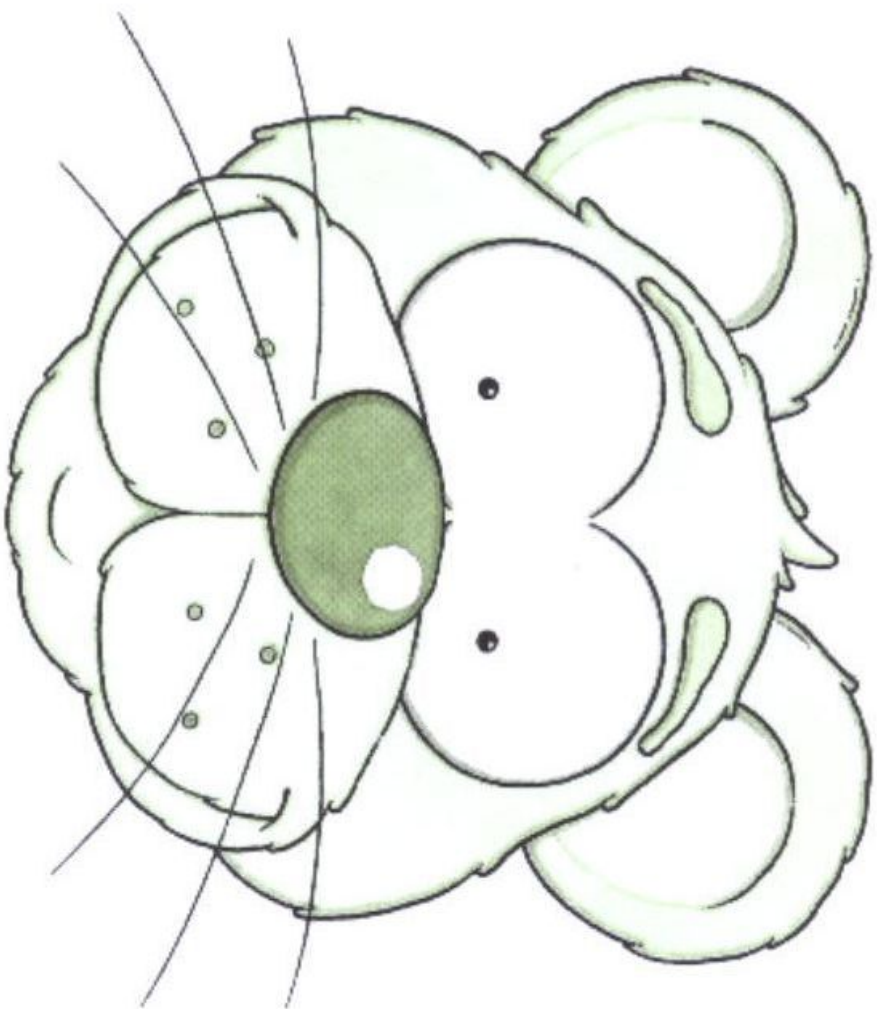



FIGURA - FONDO
Pinta el elefante.



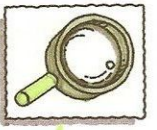
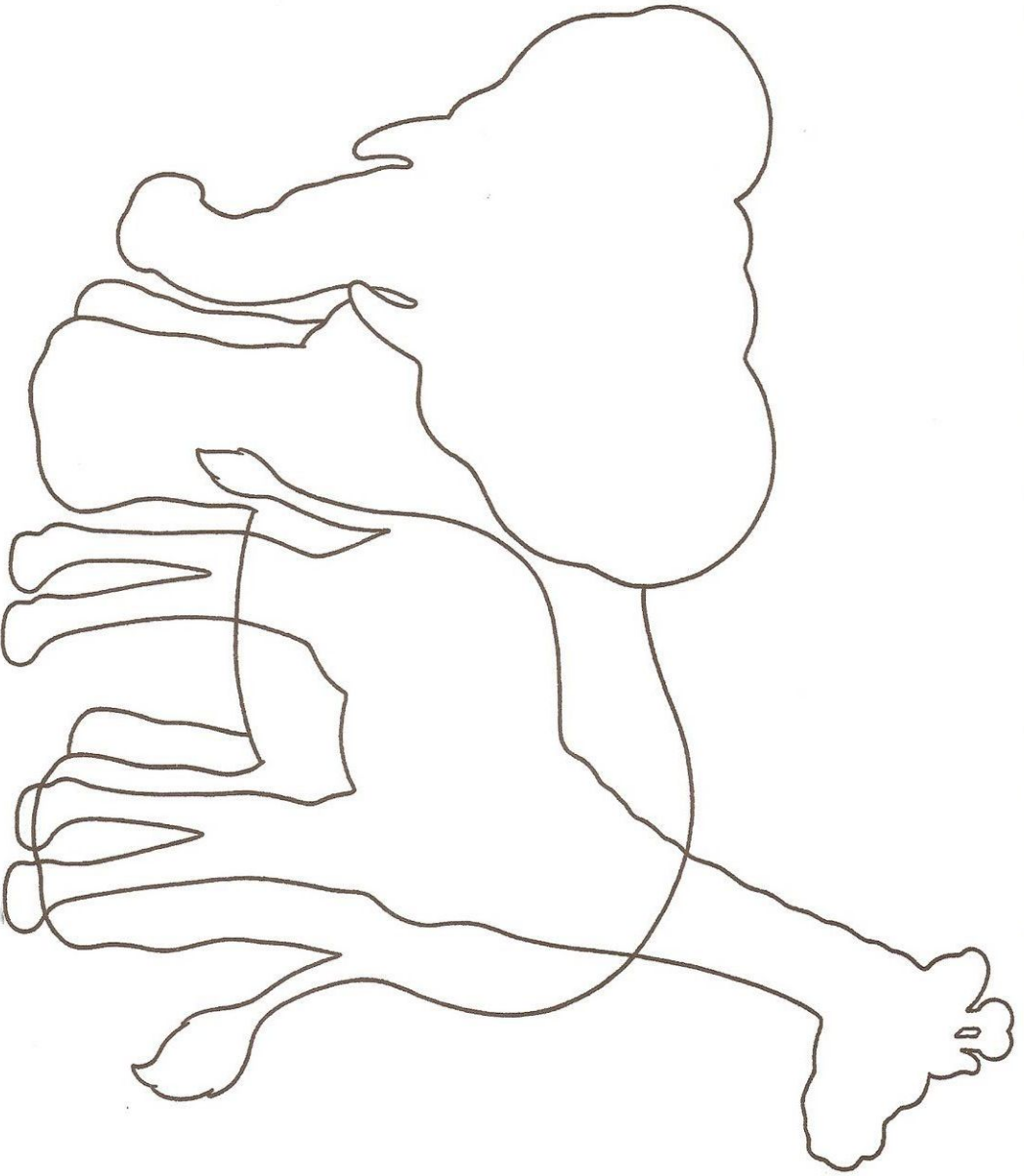
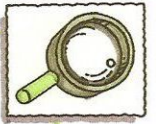

DIBUJOS INCOMPLETOS

Dibuja lo que le falta a cada animal.



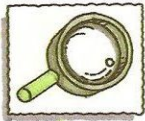

SEMEJANZAS Y DIFERENCIAS
Une con flechas los animales iguales.

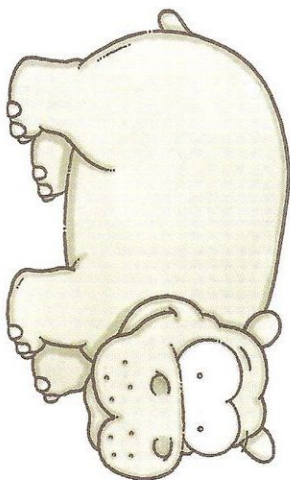
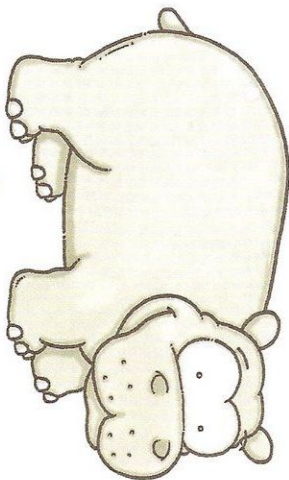

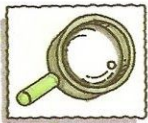

OBJETOS ESCONDIDOS

Busca en el jardín todas las flores iguales a los modelos. Píntalas.





FIGURA - FONDO

Busca la flor y pintala.



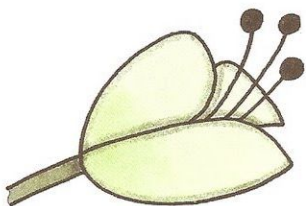
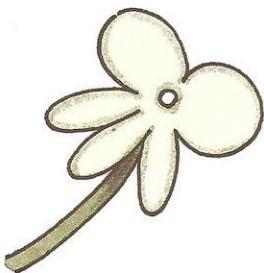
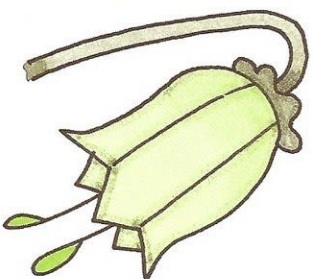
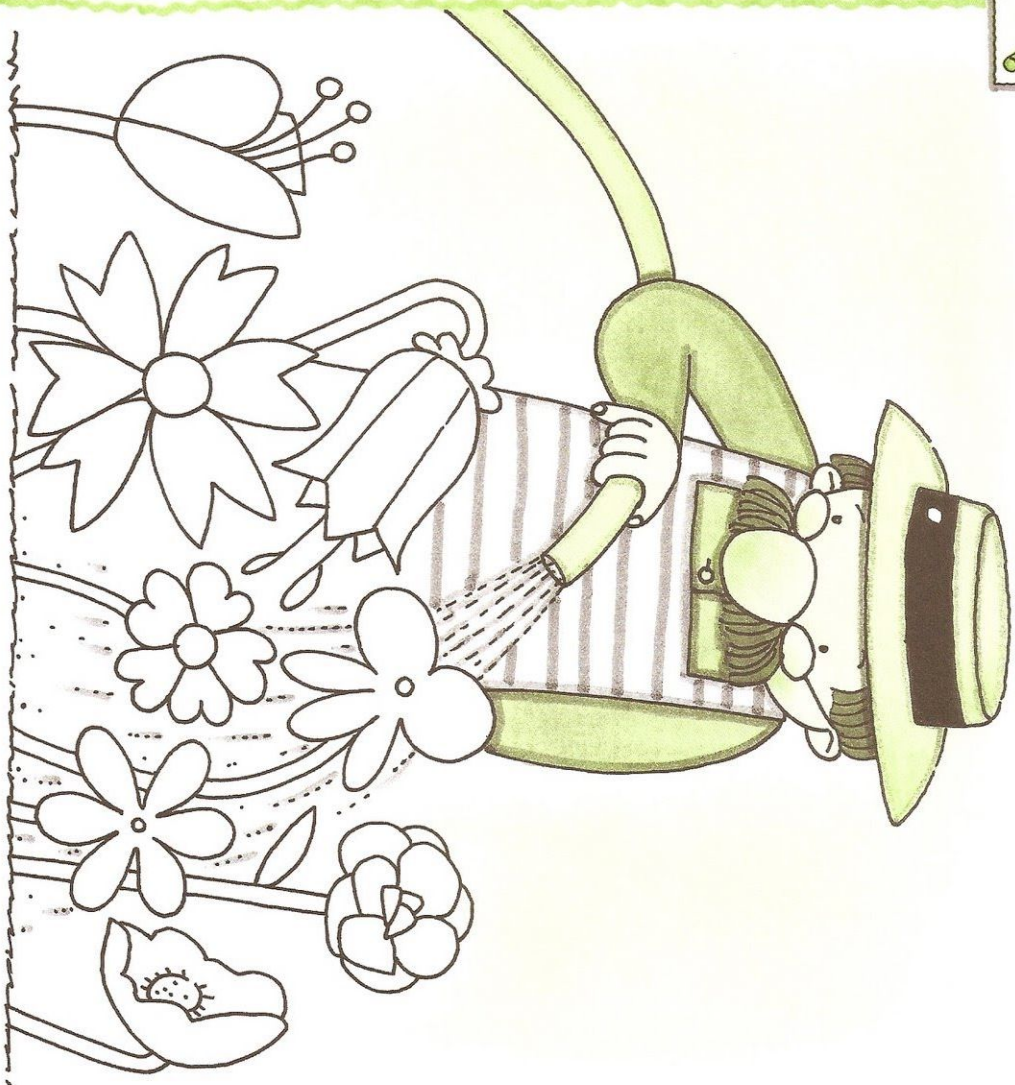
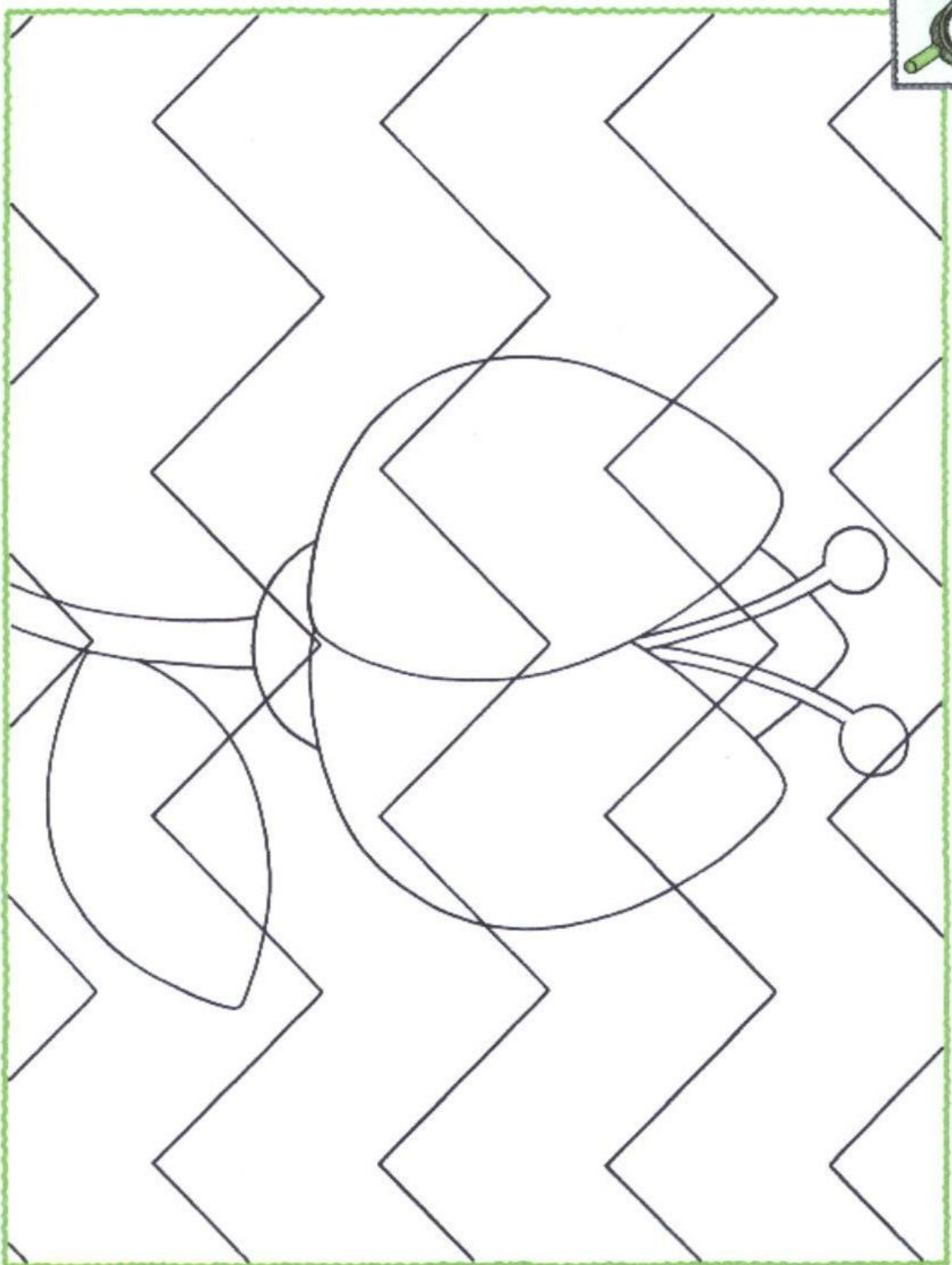

RECONOCIMIENTO DE PROPIEDADES

Pinta el árbol más grande.

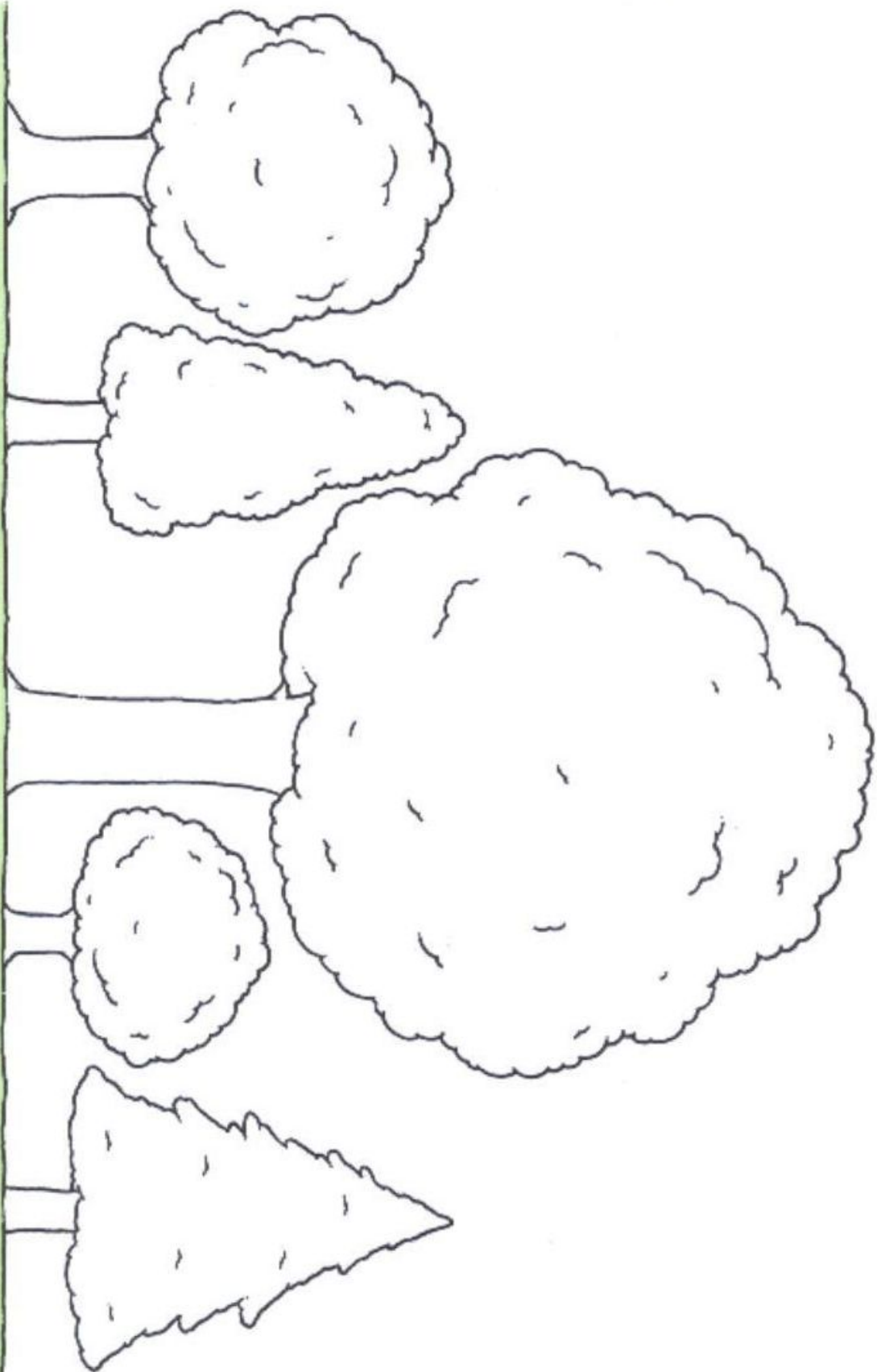

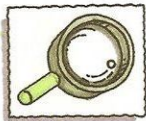

OBJETOS ESCONDIDOS
Pinta los animales del campo.





SEM EJANZAS Y DIFERENCIAS

Encierra los dibujos iguales al modelo. Tacha los diferentes.

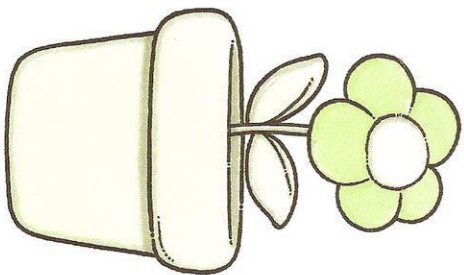
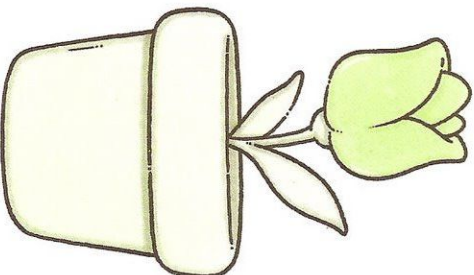
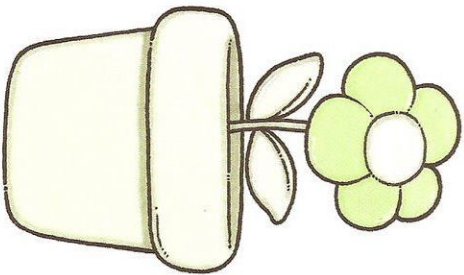
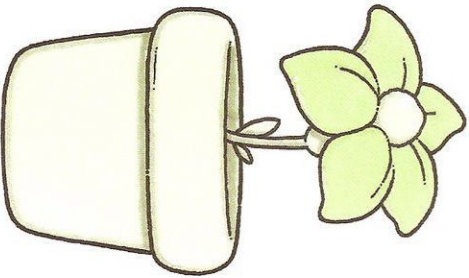
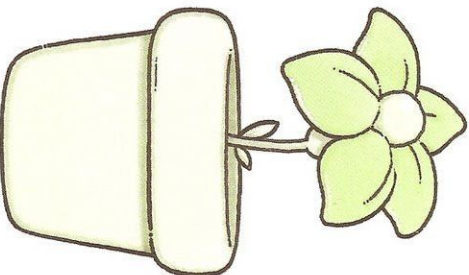
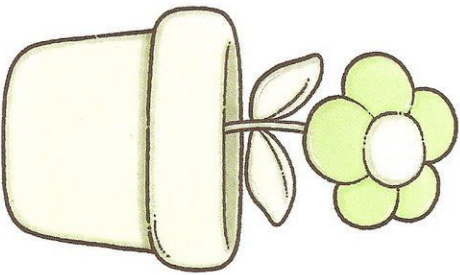
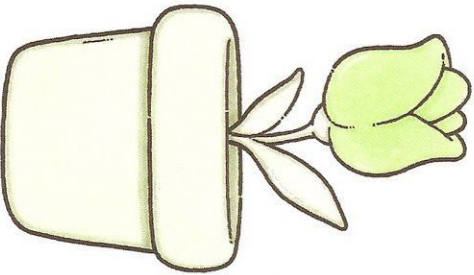
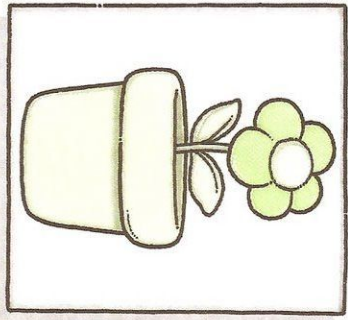

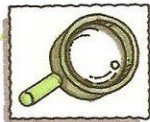

DIBUJOS INCOMPLETOS

Une con flechas lo que le falta a cada animal.

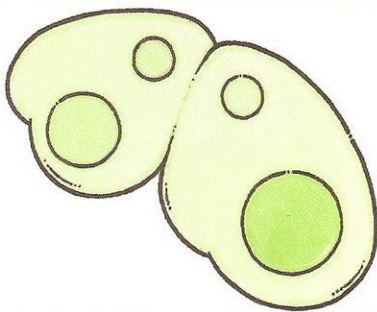
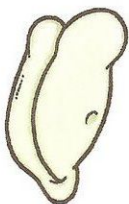
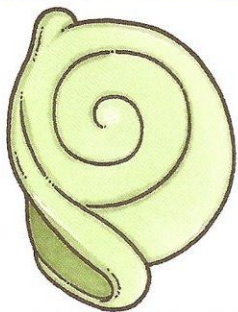
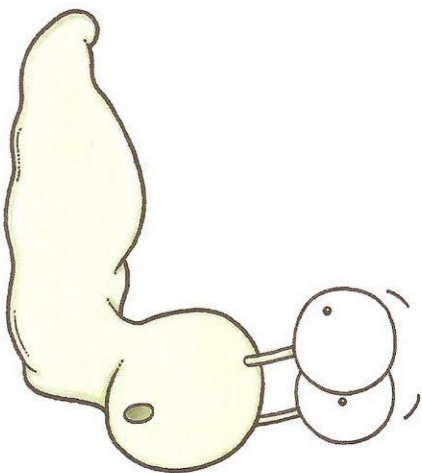
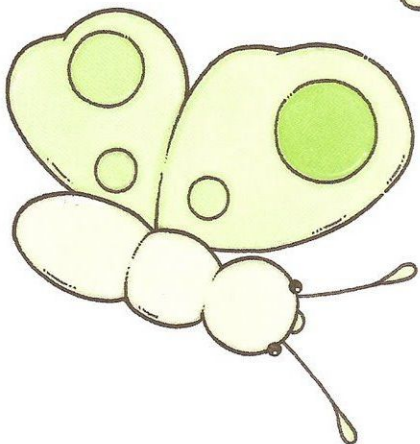
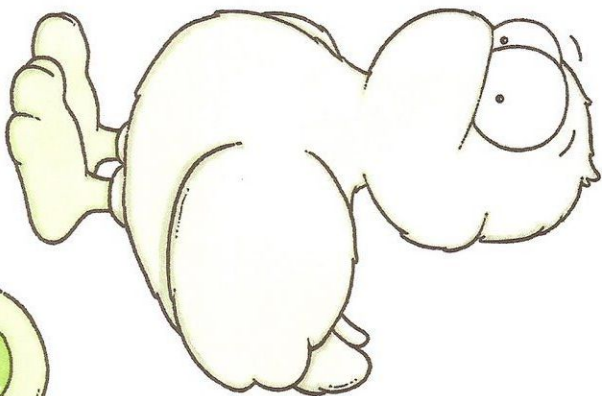

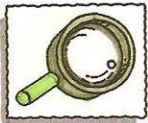

RECONOCIMIENTO DE PROPIEDADES
Pinta de amarillo el animal más grande.

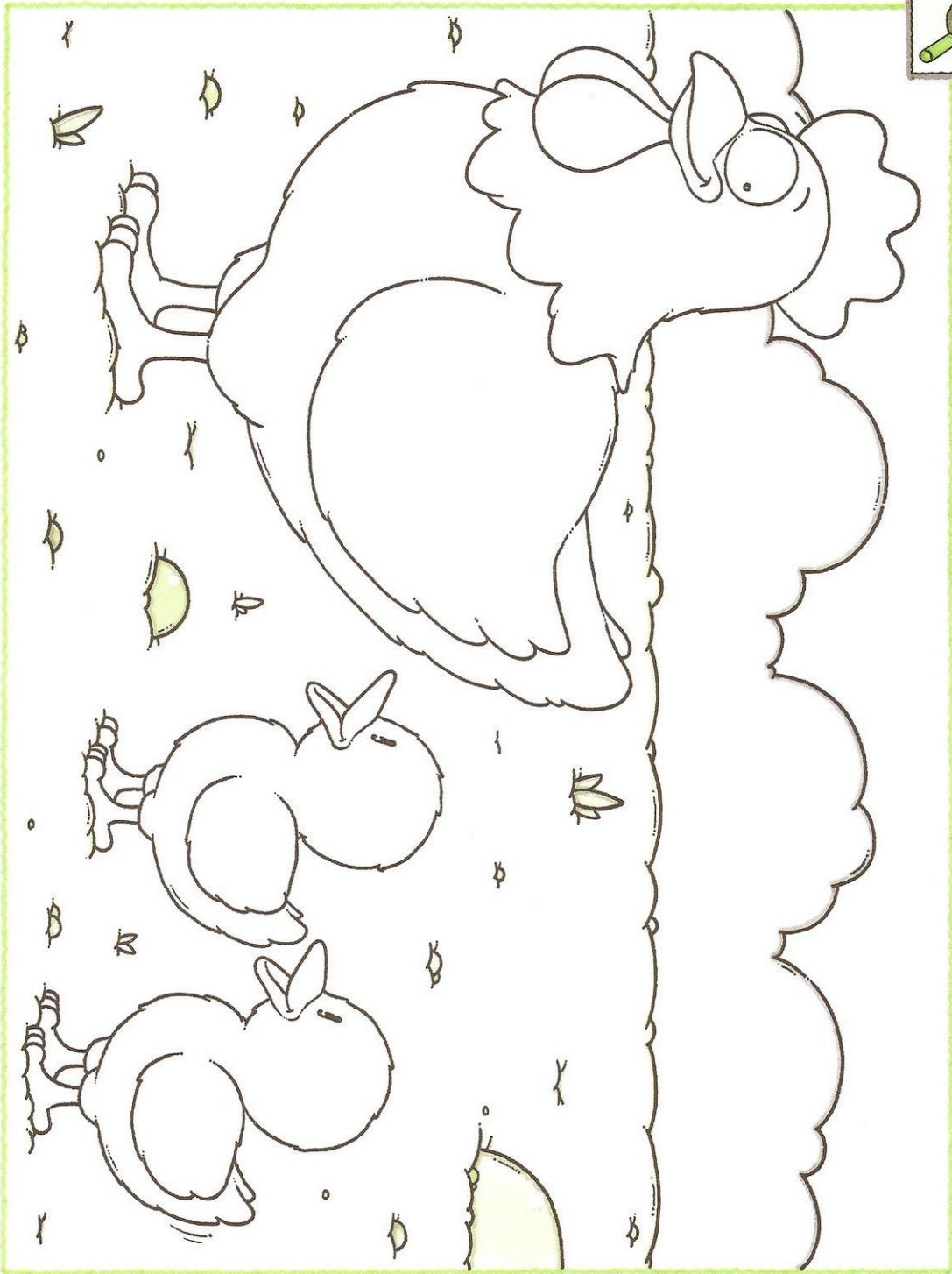



FIGURA - FONDO

Busca un animal y píntalo.



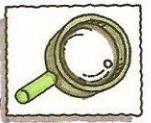
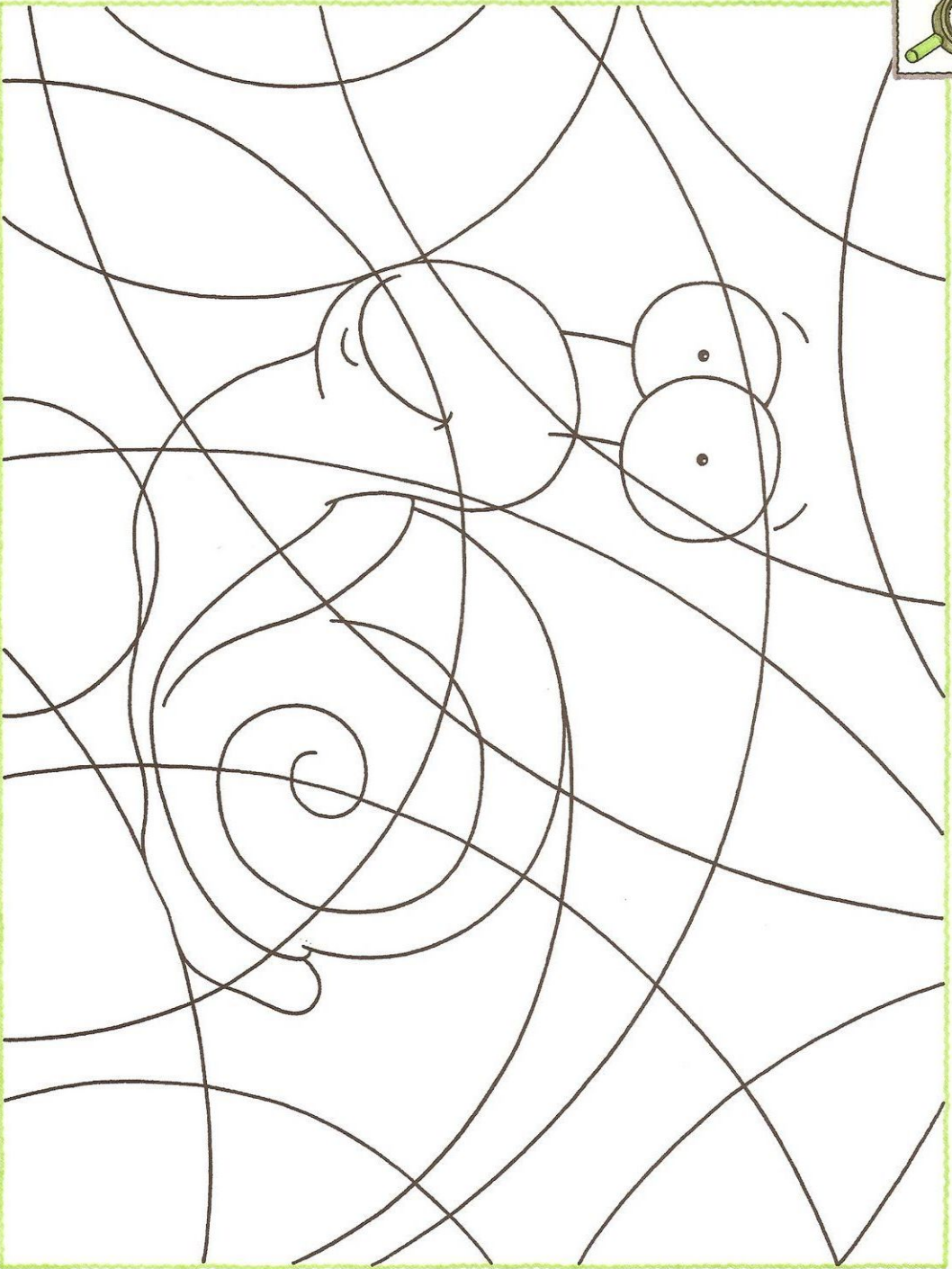
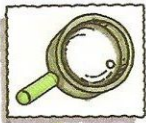

OBJETOS ESCONDIDOS

Encierra los objetos que son como los tres modelos.

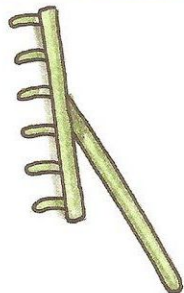
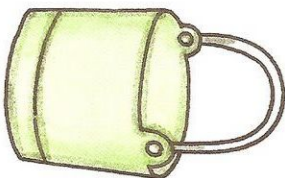

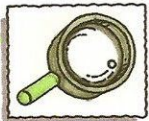

DIBUJOS INCOMPLETOS

Dibuja lo que te falta a cada animal.

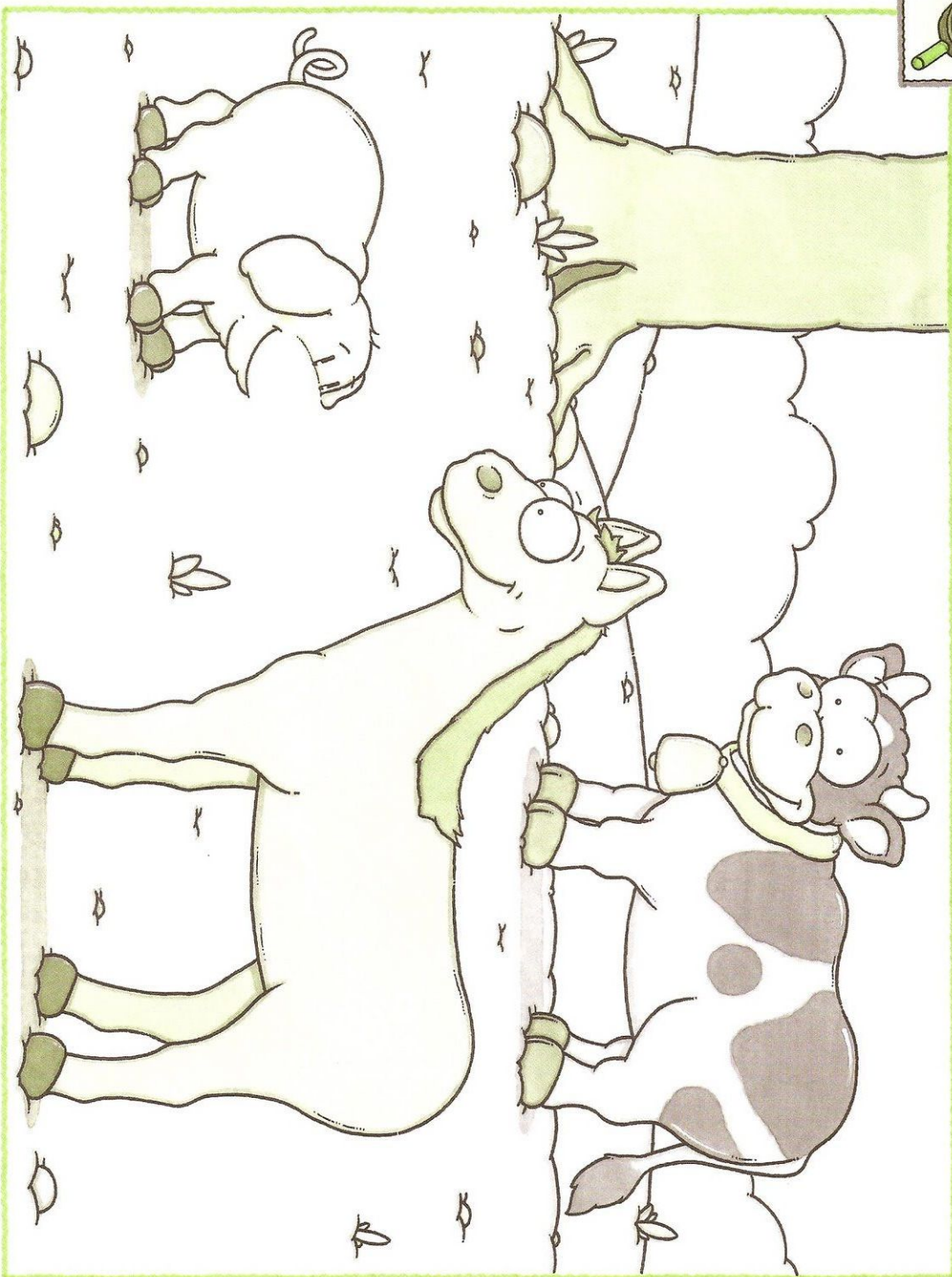

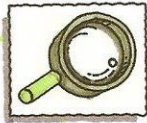

SEMEJANZAS Y DIFERENCIAS
Pinta la figura diferente al modelo.





FIGURA - FONDO

Repasa de un color diferente cada uno de los dibujos.



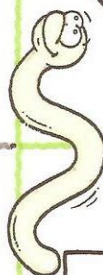
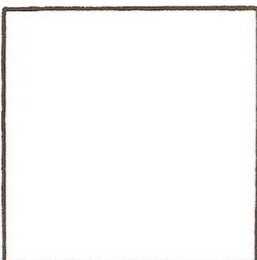
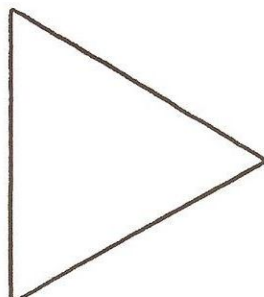
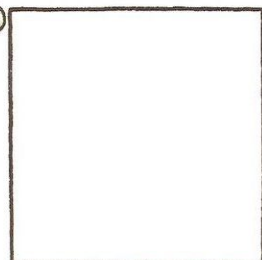
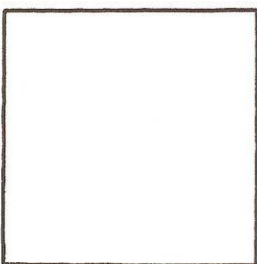
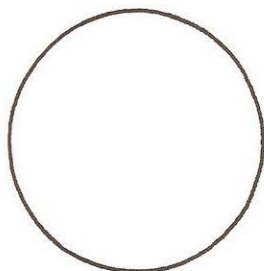
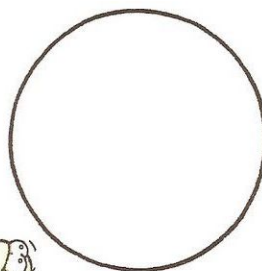
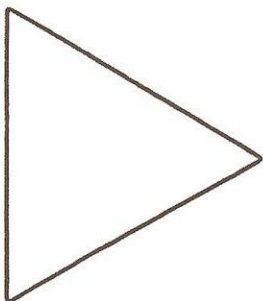
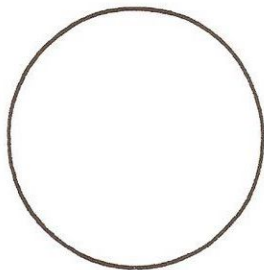
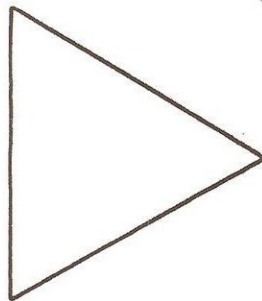
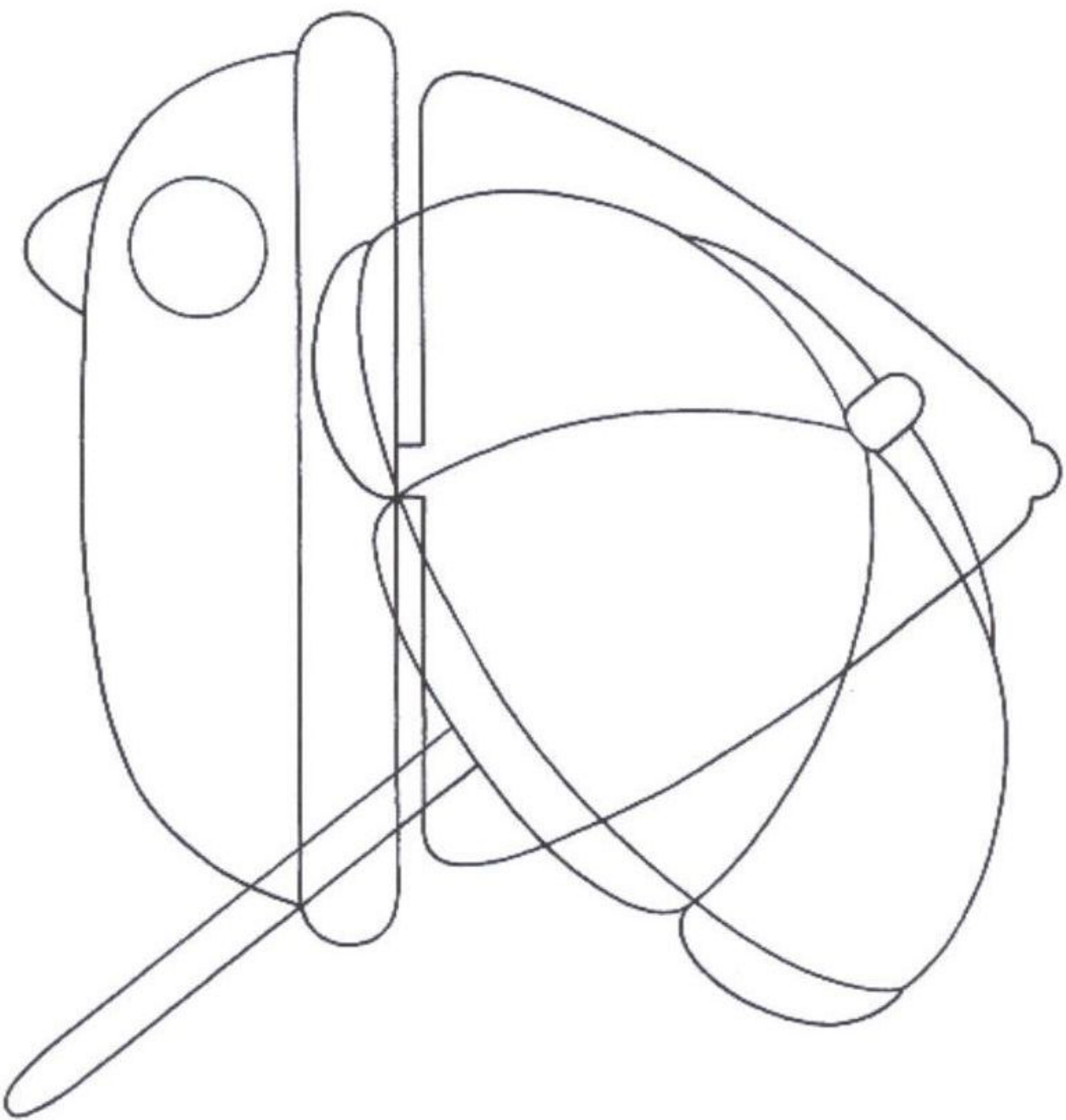
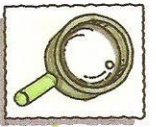

SEMEJANZAS Y DIFERENCIAS

Une con flechas las prendas iguales. Píntalas.

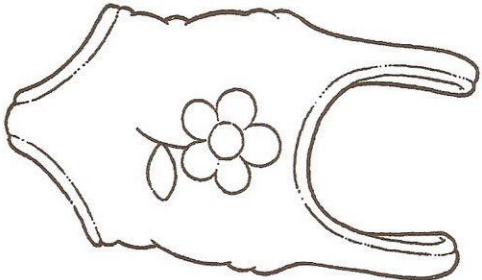
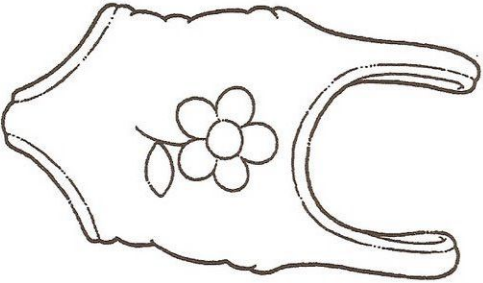
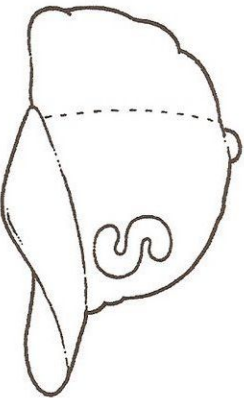
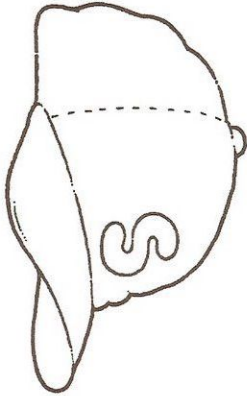
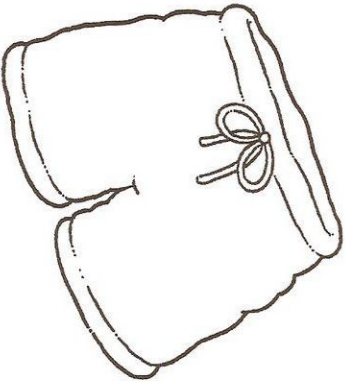
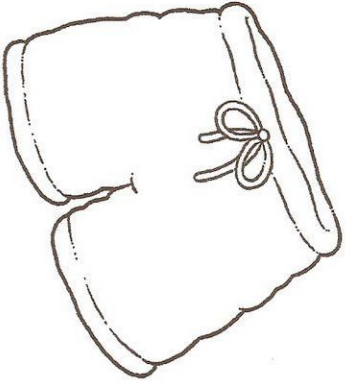

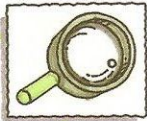

SEMEJANZAS Y DIFERENCIAS
Pinta el dibujo igual al modelo.

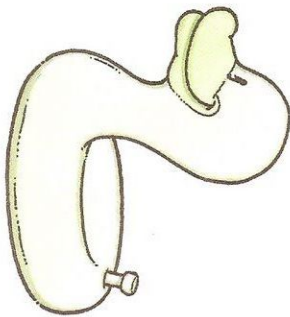
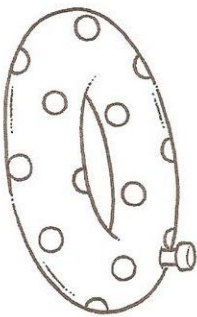
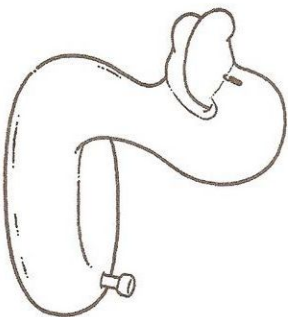
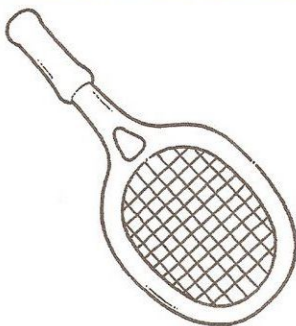
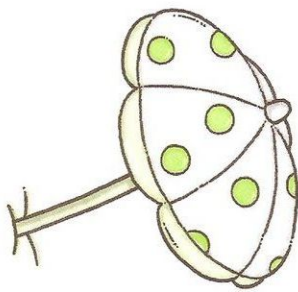
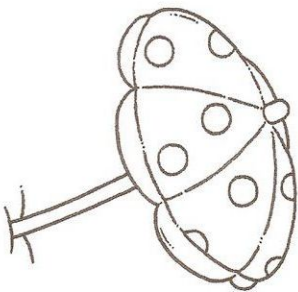
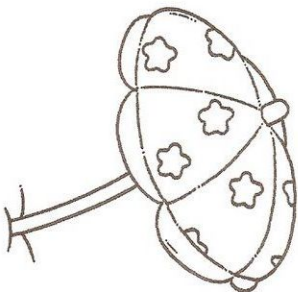
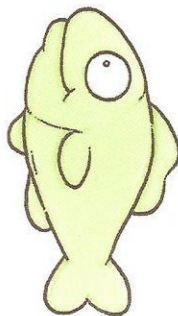
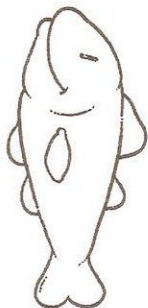
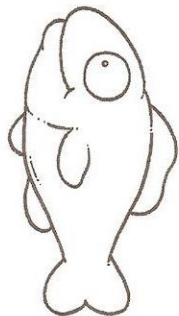

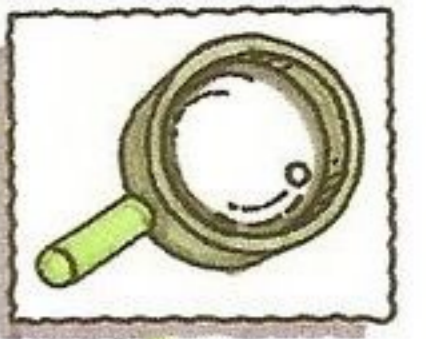

OBJETOS ESCONDIDOS

Encierra los objetos que son como los cuatro modelos.

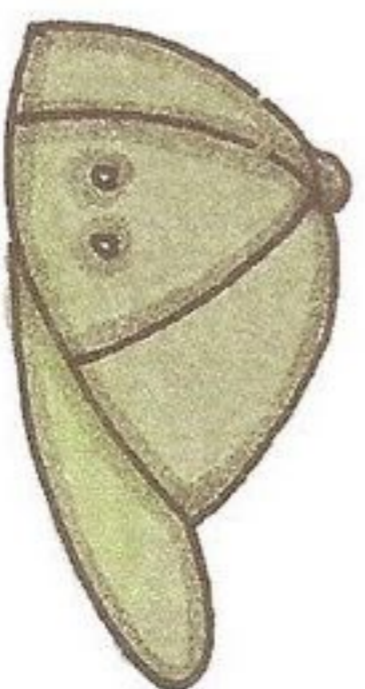
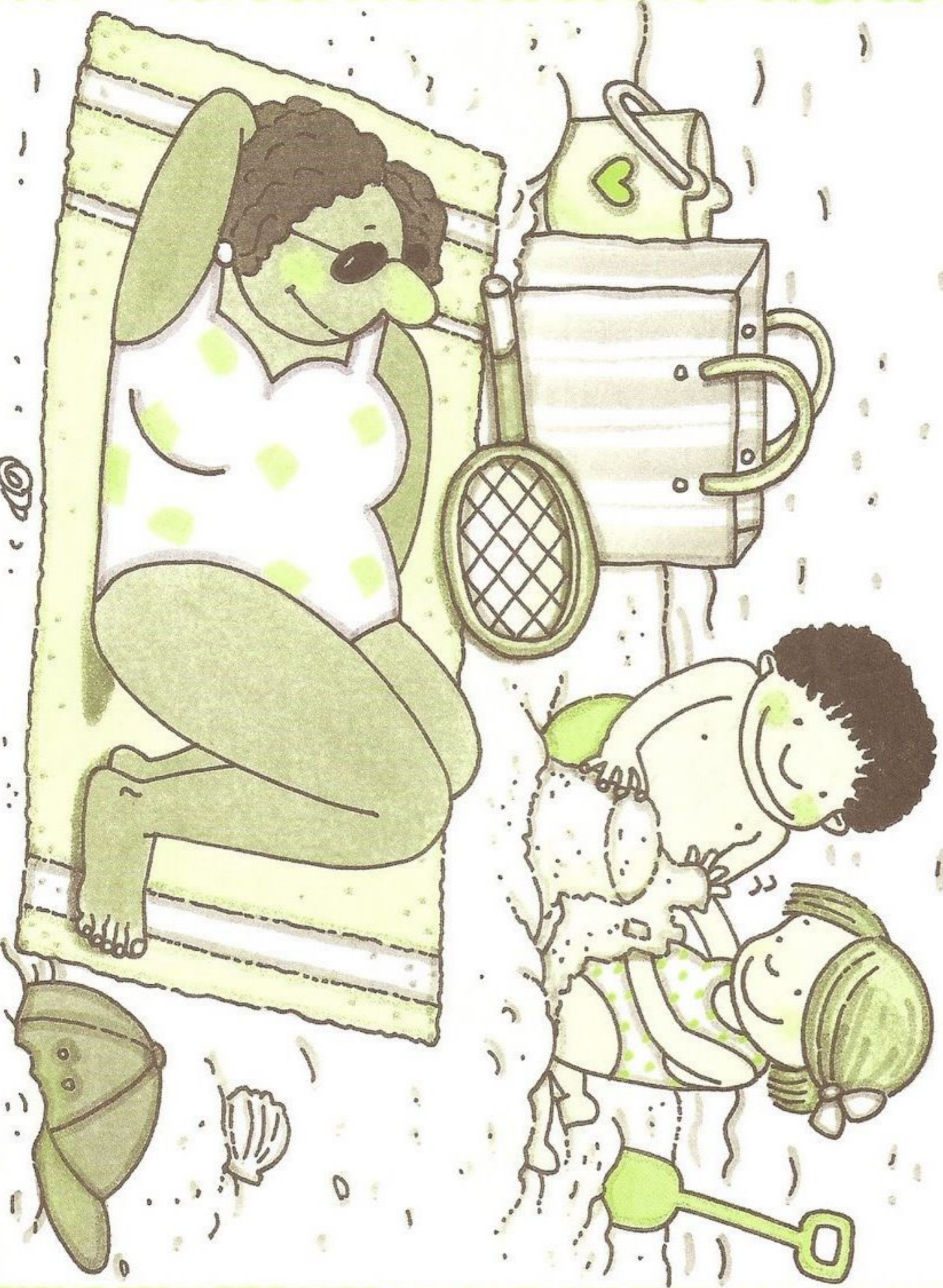
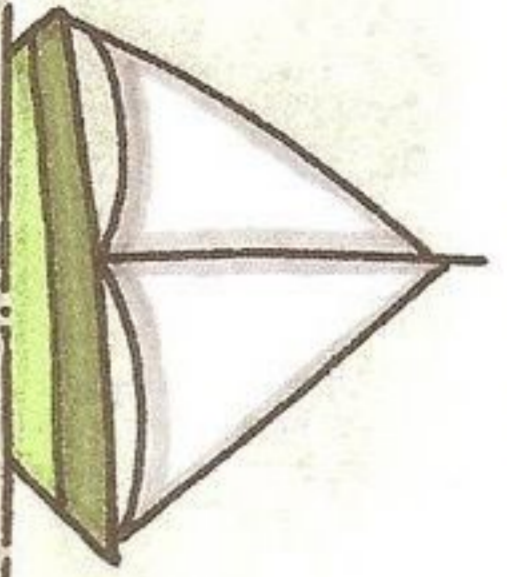

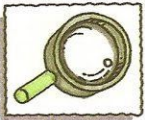

SEMEJANZAS Y DIFERENCIAS
Pinta los dibujos iguales al modelo.

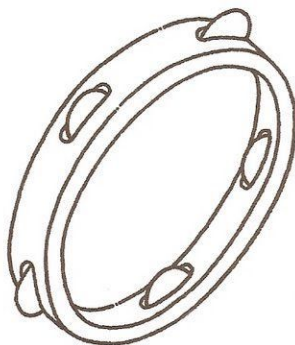
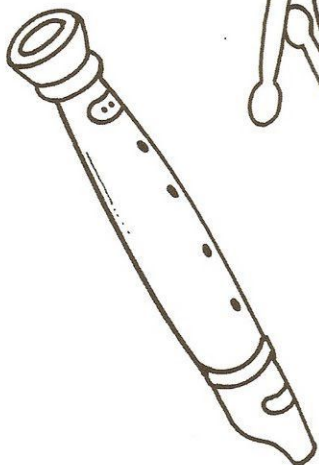
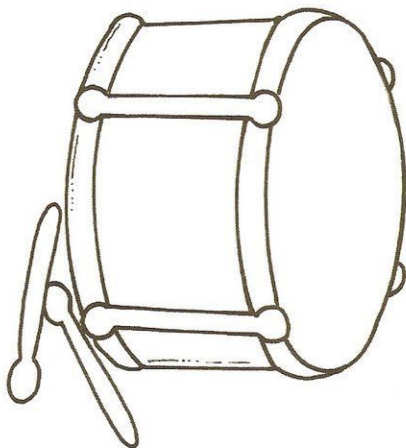
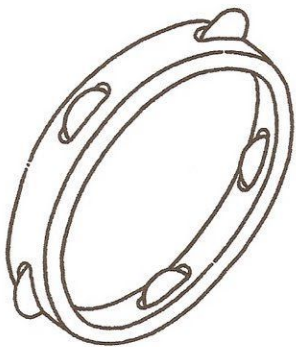
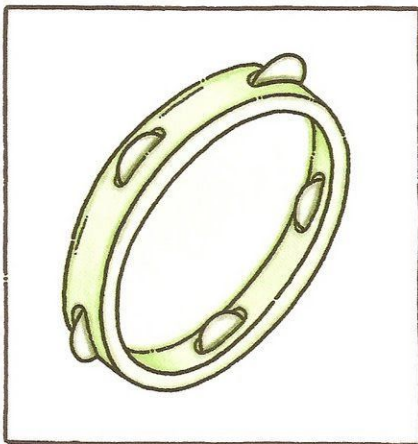

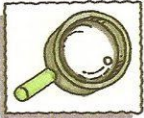

SEMEJANZAS Y DIFERENCIAS
Pinta los dibujos iguales al modelo.

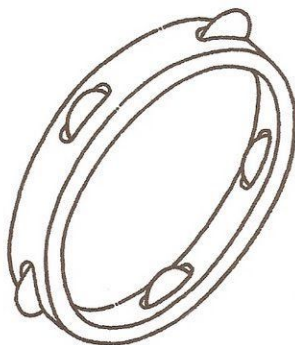
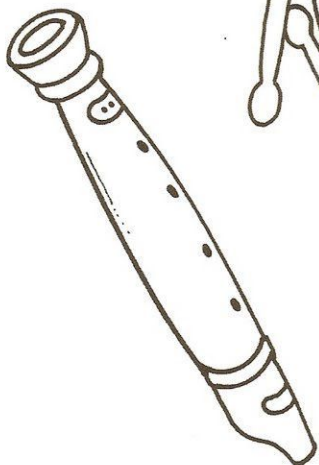
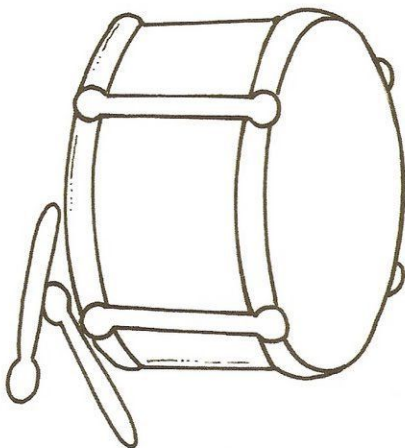
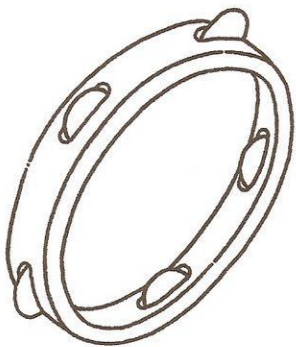
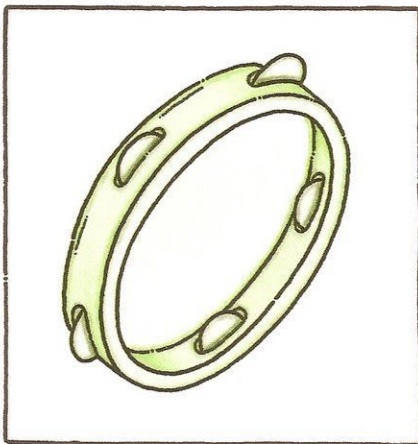

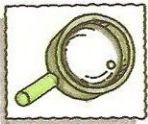

OBJETOS ESCONDIDOS

Pinta el dibujo. Encierra lo que le falta al Rey Mago.

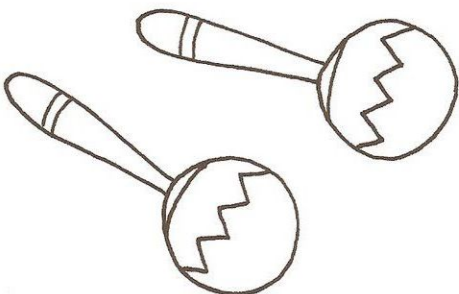
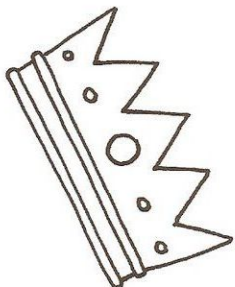
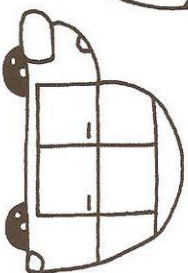
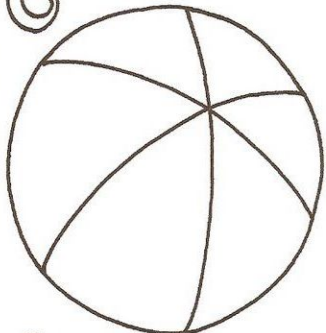
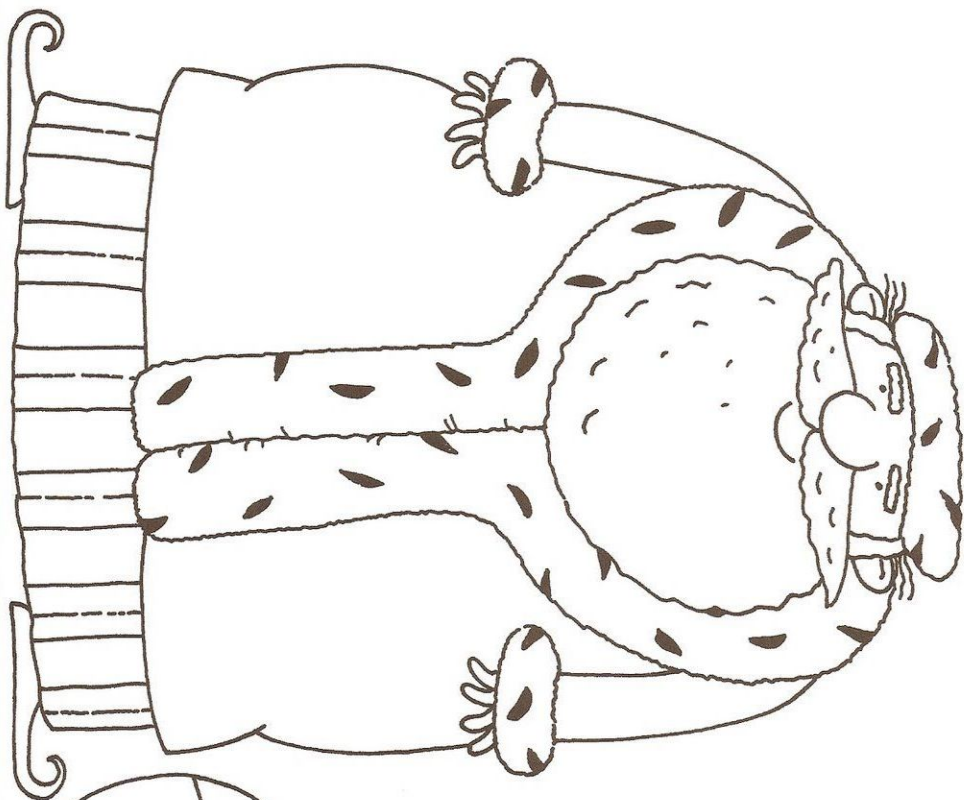



FIGURA - FONDO
Busca la oveja del pesebre y píntala.



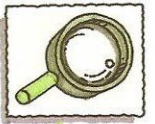
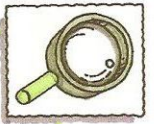

RECONOCIMIENTO DE PROPIEDADES

Pega papel lustre de color amarillo en la estrella grande.

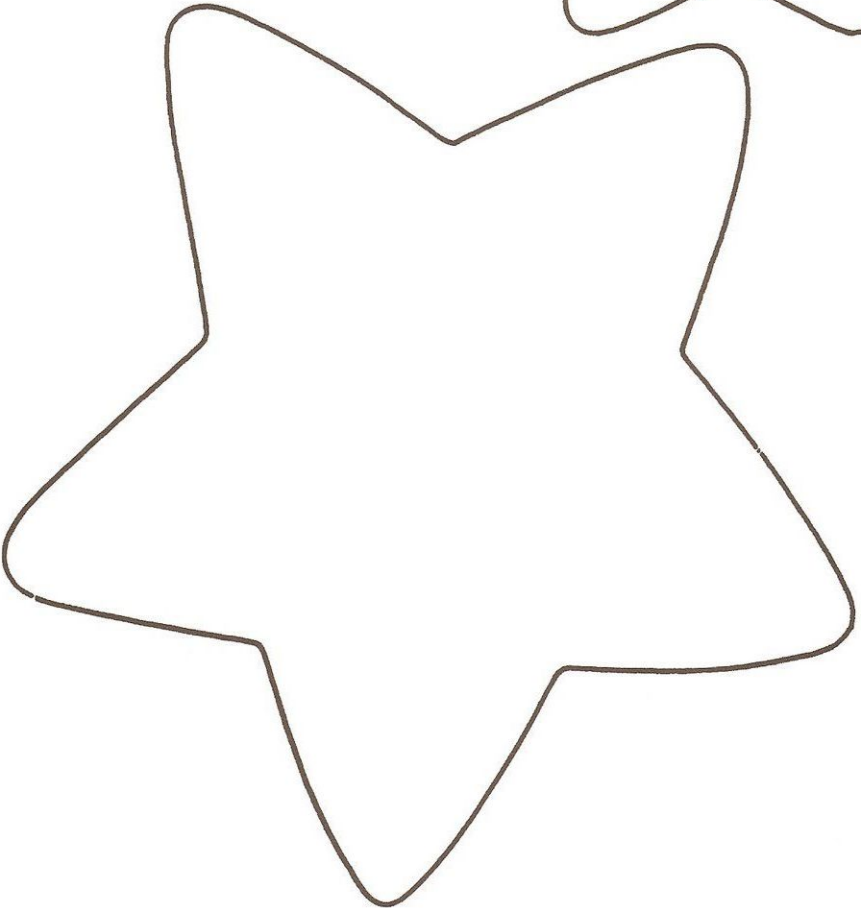



DIBUJOS INCOMPLETOS

Repasa la línea punteada para completar la campana. Píntala.

